

High-Reliability and High-Performance  
Wire Electrical-Discharge Machine

# FANUC

## ROBOCUT $\alpha$ -CiC series



High-Reliability and High-Performance  
Wire Electrical-Discharge Machine

# FANUC ROBOCUT $\alpha$ -CiC series



## ROBOCUT $\alpha$ -C400iC

XYZ axis travel : 400×300×255 mm



## ROBOCUT

XYZ axis travel :

## High Performance of Cutting

---

New mechanical structure, new discharge devices, and new discharge control to provide high speed, high precision, and high quality cutting

AI thermal displacement compensation function to provide stable cutting, and various functions to adjust shapes easily

High precision rotary table ROBOCUT CCR to expand the applications

## Maximizing Uptime

---

High reliable automatic wire feeding (AWF3) provides continuous unmanned machining

Consumables management function and Maintenance guidance function support daily maintenance

ROBOCUT-LINK*i* provides Production and Quality information management

## Ease of Use

---

FANUC CNC and operation guidance function provide superior operations

Fulfilling EDM technologies support high speed, high precision, and high quality cutting

Automatic functions support set-up operations



**α-C600iC**  
600×400×310 mm

**ROBOCUT α-C800iC**  
XYZ axis travel : 800×600×310 mm

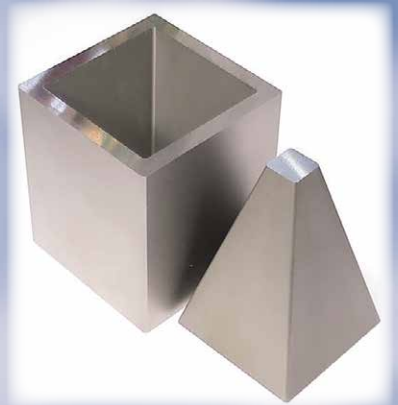
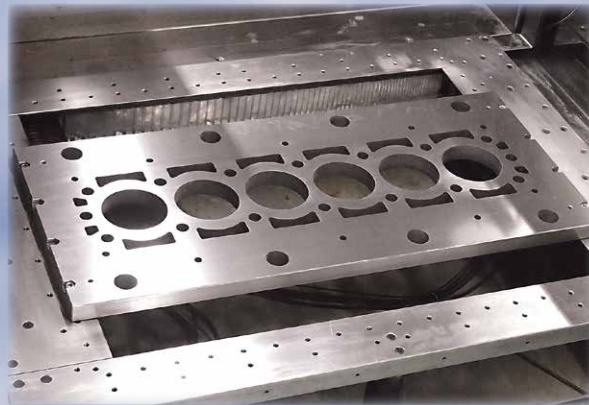

\* The outer view will be different as machine specifications



# High Performance of Cutting

## Mechanical structure to provide high precision cutting

- The strengthened machine rigidity suppresses the distortion of each part of the machine and will provide high precision cutting such as circle shape, pitch accuracy, and so on.

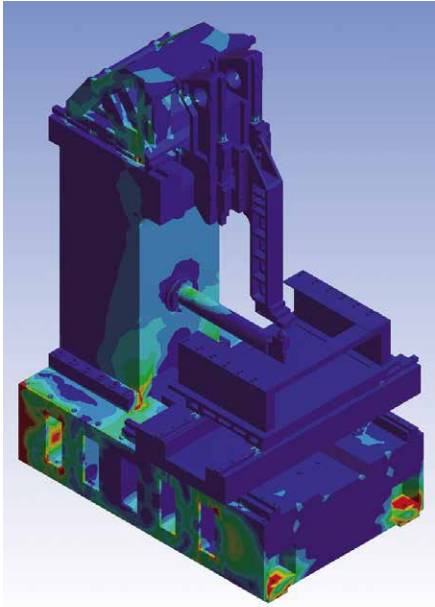

FEM analysis

### 【High precision cutting of circle shape】

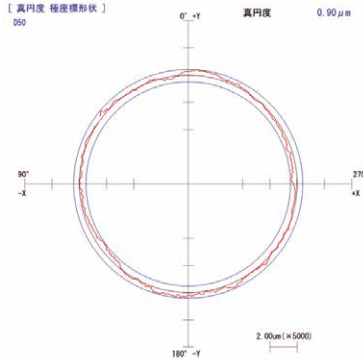

Die steel, 20mm  
1 rough 5 skims  
Roundness 0.90 $\mu$ m

### 【High precision pitch cutting】

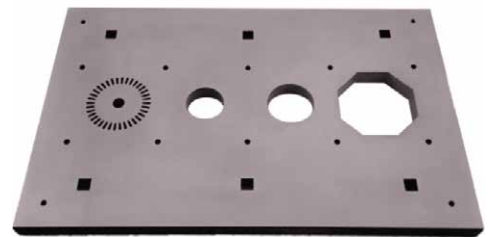
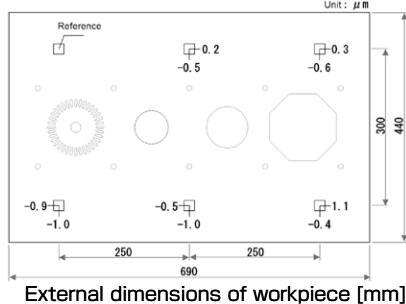

Die Steel, 30mm,  $\phi$ 0.20 brass wire  
1 rough 4 skims, 20mm square holes  
Pitch accuracy: X -0.9 to 1.1 $\mu$ m, Y -1.0 to 0.0 $\mu$ m

## Discharge device to provide high quality cutting

- SF3 power supply (standard installed) generates both miniaturization and high frequency of discharge pulse to improve surface roughness while the cutting speed is kept the same
- MF2 power supply generates the stable fine discharge to provide the best surface roughness

### 【Discharge wave by SF3】

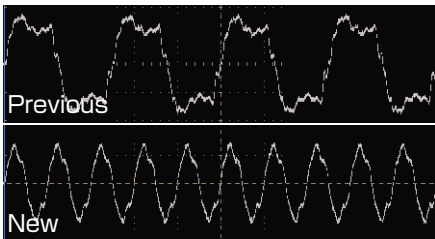

### 【The best surface roughness by MF2 (option)】



Carbide, 30mm  
1 rough 8 skims  
Rz 0.7 $\mu$ m (Ra 0.10 $\mu$ m)

## Discharge control to provide high precision cutting

- Discharge control *i*Pulse3 provides high precision cutting even while nozzle is open.

### 【Overview】



Nozzle clearance  
Top : 15mm

Nozzle clearance  
Bottom : 5mm

### 【Cut sample】

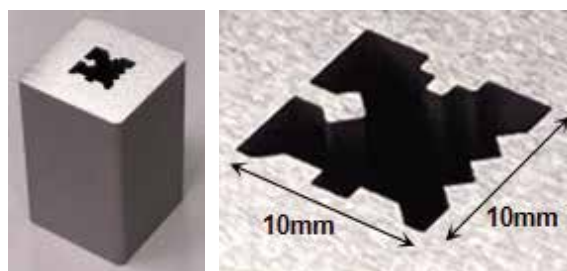

Dis steel, 40mm,  $\phi$ 0.20 brass wire, 1 rough  
4 skims, Accuracy  $\pm$ 2 $\mu$ m, Roughness Ra 0.30 $\mu$ m

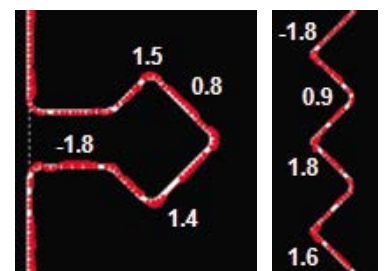

Measured result  
(Deviation at top surface)

## Various functions and mechanisms to support high precision cutting

### High precision positioning function

- Workpiece edge finding function with wire by applying the latest position detection method



### Taper adjustment function (Max. 4 directions)

- Simple setup for high precision taper cutting



Die steel, 50mm  
1 rough 3 skins  
Taper angle 20 degrees

Measured angle(4 directions)  
+X 20.001 degrees  
-X 20.007 degrees  
+Y 19.998 degrees  
-Y 20.009 degrees

### High precision pitch error compensation function

- Corrects the pitch error over the entire table area

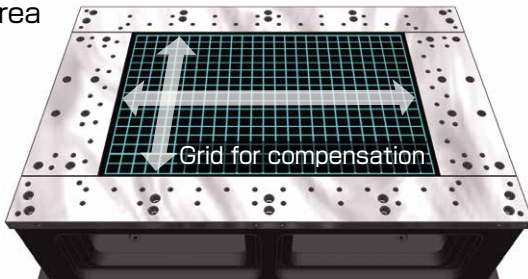

### Workpiece table (standard installed)

- Durable table to prevent scratch

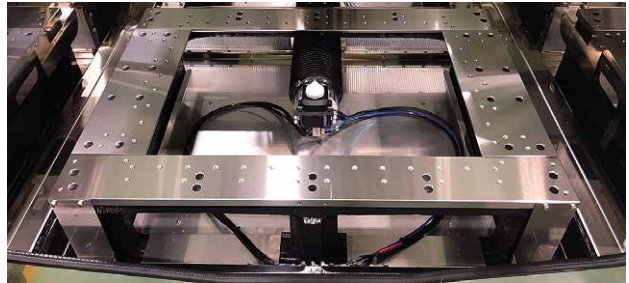

## AI thermal displacement compensation function to realize stable cutting

- Multiple temperature sensors and AI (Machine Learning) realize stable cutting even if the temperature around the machine changes on a large scale.

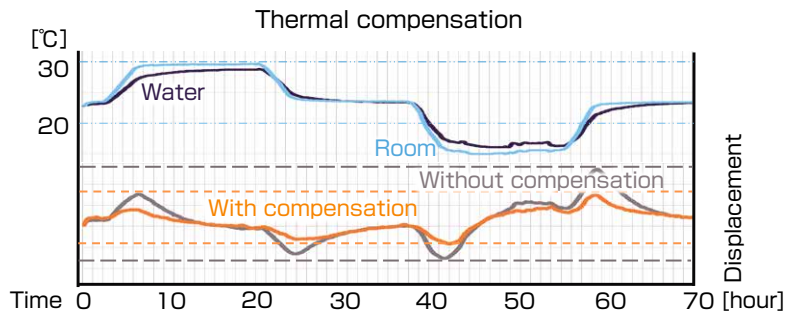
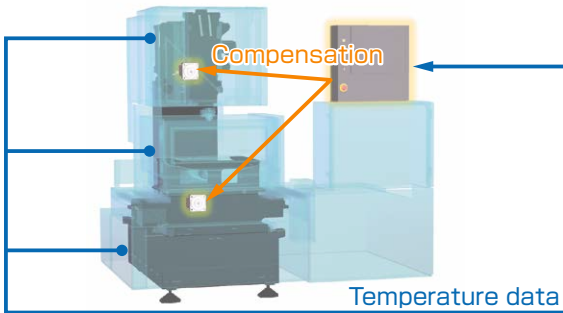

## High precision rotary table, ROBOCUT CCR, to expand applications (Option)

### ROBOCUT CCR

- FANUC Servo motor & rotary encoder are installed



High precision positioning, light weight, and compact rotary table



【Cut sample】  
Helical cutting

### PCD tool cutting

- PCD tool applications with ROBOCUT CCR



High quality cutting by PCD dedicated power supply

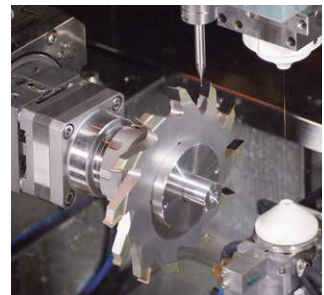

# Maximizing Uptime

## Automatic wire feeding system AWF3 to support unmanned operation

- Simple structure provides a great maintainability, higher rate of wire threading, and high reliability
- Provides AWF for Max.400mm height in submerged condition, AWR with 150mm work thickness

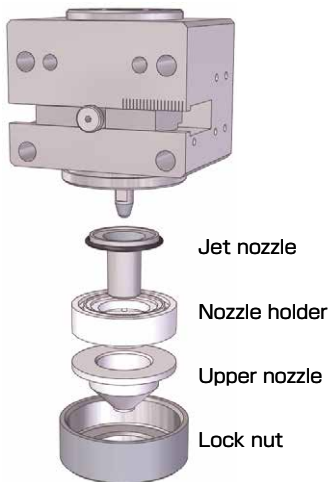
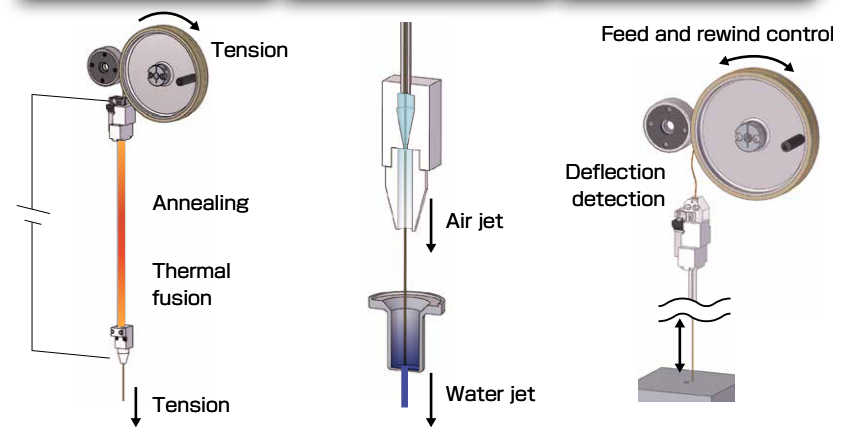

Simplified upper guide unit

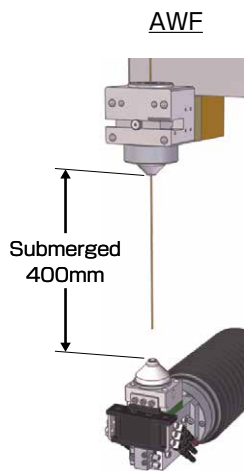

AWF

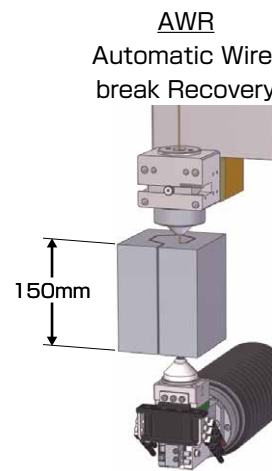

AWR Automatic Wire break Recovery

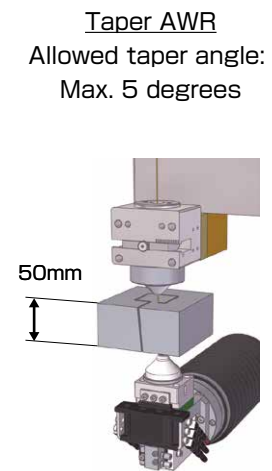

Taper AWR Allowed taper angle: Max. 5 degrees

Various AWF functions support strongly unmanned operations

\* All AWF obtained under FANUC-designated conditions

## Level up performance of AWF

- Improved straightness of wire to shorten time for threading wire into small hole or wire break point while nozzle clearance is open.
- Vibrates wire tip during threading for various cases such as threading wire into shifted start hole or hole with burr inside (called air retry)

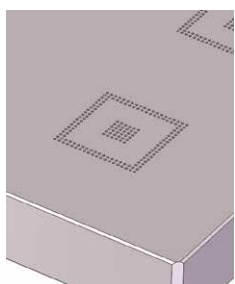

Min. hole size:  $\phi 0.3\text{mm}$

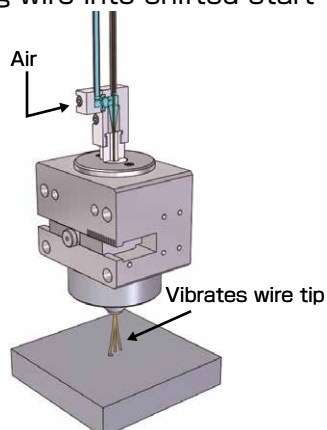

## Twin servo wire feeding system

- Wire feeding system with FANUC servo motors accurately controls the wire tension and suppresses the wire vibration to provide high precision cutting

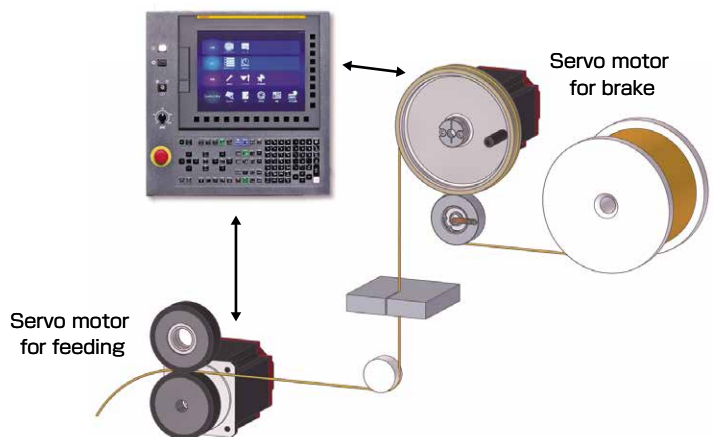



## Wire running system to contribute for higher rate of operation

- Simple structure to provide easier wire installation

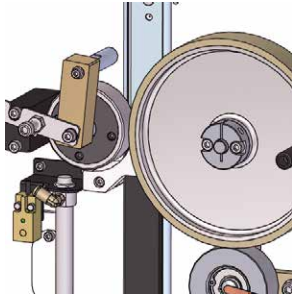

- Maintenance-free structure on the lower guide

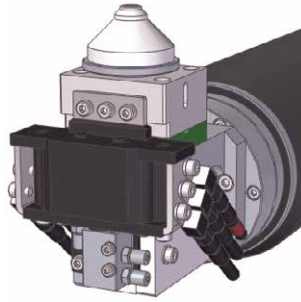

- 50%\* shortened maintenance time at wire outlet mechanism  
\* Compared to previous model

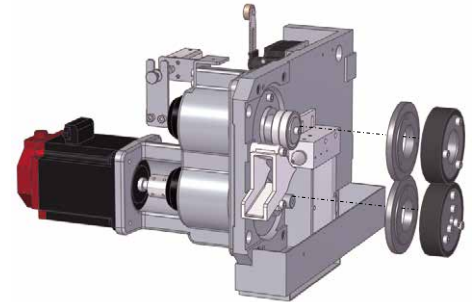

## CORE STITCH\* function to adhere the cores

- The function to adhere the core by brass welding provides continuous unmanned operation.
- Prevents the machine damage from the dropped cores

- Easy operation to activate on the CNC screen
- Easy setting of adhesion distance and gap

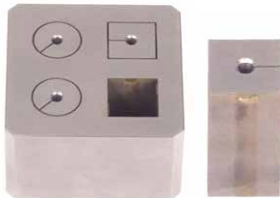

Core adhesion and a removed core

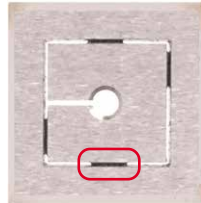

Adhesion by brass ingredient

\*CORE STITCH is a registered trademark of Seibu Electric & Machinery Co., Ltd.

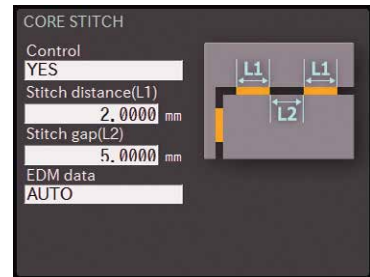

## Pre-seal mechanism for work tank to provide high reliability

### Pre-seal mechanism

- Pressurized clean water tank prevents the seal plates from sludge adhering to it
- Reduces frictional resistance to prevent from deteriorating cutting accuracy

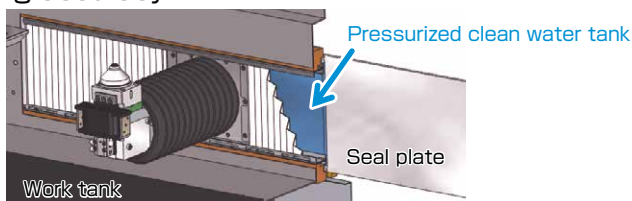

### Two-split Transparent seal plates

- Easy to disassemble and keep clean
- Easy to check how much dirty

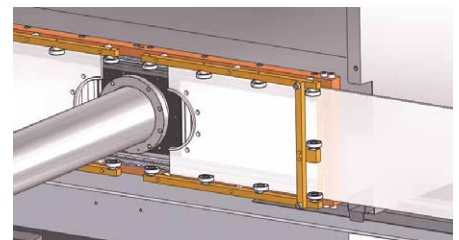

## ROBOCUT-LINK*i* to manage production and quality information

- Monitors the cutting status of ROBOCUT in real time
- High speed transfer of NC programs
- Notifies the job end or alarms to operators by emails

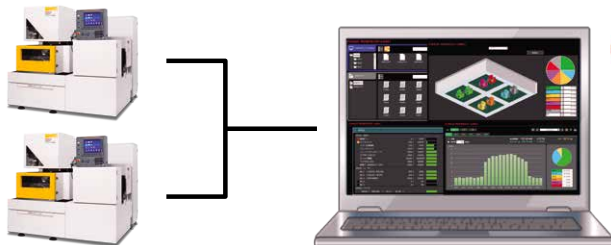

32 units connectable



Overall monitoring



Operation result



Consumables' lives



Power consumption monitor

\* OS : Microsoft® Windows® 7 / 8 / 8.1 / 10 / 11 \*\* It's necessary to contract with provider to use email function.

# Ease of Use

## FANUC's latest CNC to improve operability



### PANEL iH Pro, the high performance display unit of FANUC

- Provides 75% faster drawing speed than previous model

Previous



PANEL iH Pro



75% time savings

- Multi-touch screen to support operation
- Undo/Redo function will save the operation mistakes
- ROBOCUT-CAMi installed in the PC can be remote-operated from ROBOCUT screen

### Simple adjustment function

- Cutting speed and the shape can be adjusted by simple and intuitive operation



Touching the buttons to adjust the EDM parameters



The cutting speed can be adjusted from 50% to 120% keeping the discharge gap to achieve stable cutting

The buttons to adjust visually at the corner shape and approaching shape without directly changing parameters

## Customize functions to support user needs

### Custom PMC

- Ladder programs for peripheral devices can be created on the screen

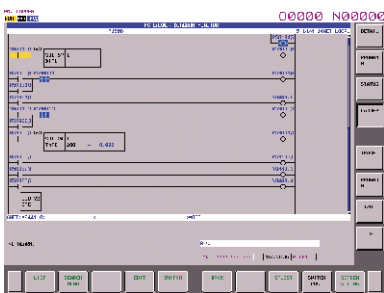

※Standard I/O : 8 points each

### Custom screen

- Original applications created by yourselves can be installed and operated on ROBOCUT



※Designated software is necessary.



## Automation system with FANUC Robot (Option)

- 4 units of ROBOCUT with one Robot are connectable through FL-net
- Easy setup of workpiece exchange system by Robot
- Automation system for high-mix low-volume production

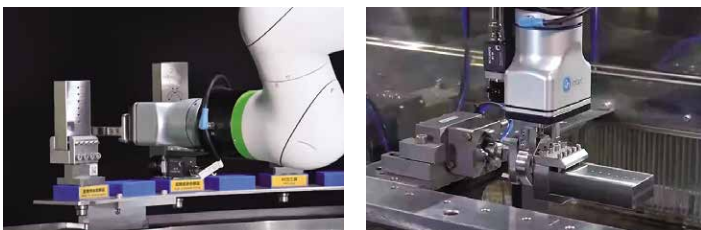

Workpiece exchange system with FANUC Robot (sample)



## Various functions to support setting up

### Setup Guidance function

- Explains the set up procedure



### Searching EDM screen

- Provides the proper EDM technologies to each application



### Smart Programming

- Simple operation to make NC programs automatically



### 3D Coordinate Rotation Function

- Compensates the wire vertical position by moving U / V axes according to the workpiece tilt.

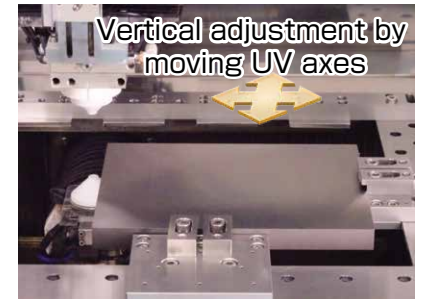
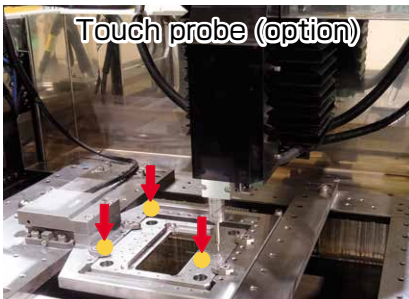

## Various functions to support daily maintenance

### Consumables management

- For monitoring the lives of consumable parts



### Maintenance guidance

- Provides the daily maintenance with pictures etc.

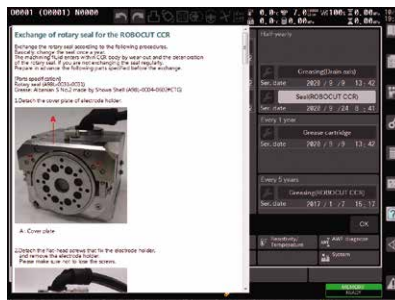

### Parts list

- For searching maintenance parts and ordering information

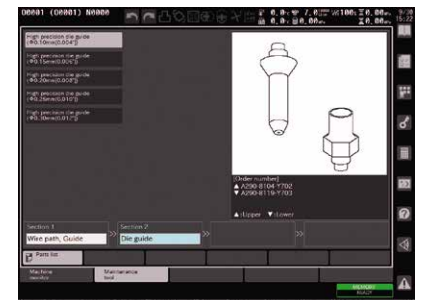

## ROBOCUT-CAMi (Option)

- This is the PC software to create NC programs for ROBOCUT
- Easy operation to make NC programs interactively for standard cutting, taper cutting, different profiles on the top and the bottom cutting, gear shape cutting, CORE STITCH, and so on
- Easy operation to create cutting path from CAD data (DXF,IGES,STEP) and NC programs
- Standard EDM technologies for ROBOCUT are installed
- USB memory and Ethernet are allowed to use when transferring the data between ROBOCUT and the PC

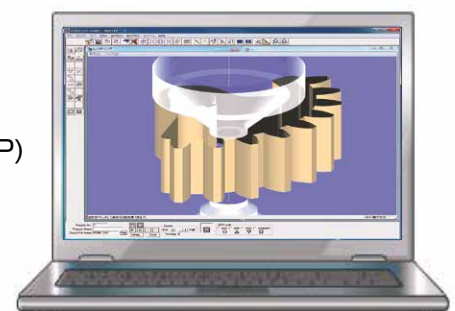

\*OS : Microsoft® Windows® 8 / 8.1 / 10 / 11

# Options



Linear encoder



MF2 power supply for skim cutting



PCD tool cutting system



Double doors

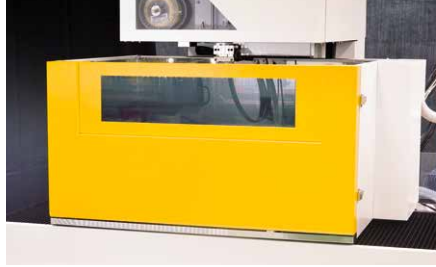

Automatic door



45 degrees taper kit



Work light (LED)



Warning light (Three-stage LED with buzzer)



Automatic grease lubrication

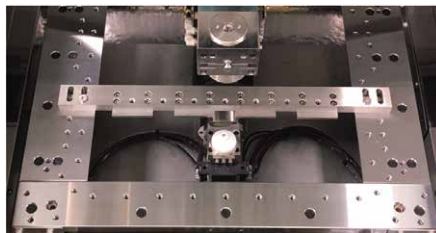

Removable table (α-C400iC)



Wire loader (Max. 30kg)

\* The availability of options is different, depending on the country, region, model, Please contact FANUC.

# Service & Support

## Excellent Maintenance Services

FANUC service team delivers customer trust and confidence based on direction of service "Maximizing Uptime", "Global Service" and "Lifetime maintenance".

**Service First**

Conforming to the spirit of "Service First", FANUC provides lifetime maintenance to its products for as long as they are used by customers, through more than 270 service locations supporting more than 100 countries and regions throughout the world.

Maximizing Uptime



Global Service

Lifetime Maintenance

## FANUC ACADEMY

FANUC ACADEMY operates training programs on FANUC ROBOCUT which focus on practical operations and programming with cutting know how and maintenance.



# Floor Plan

## α-C400iC

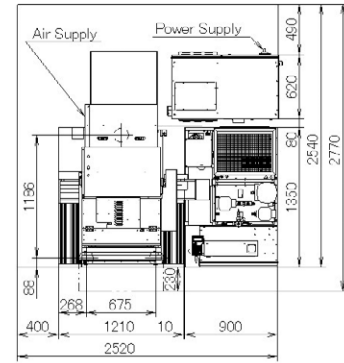
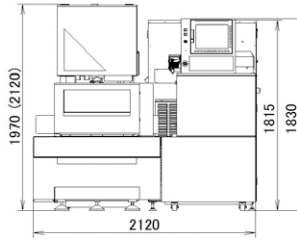

## α-C600iC

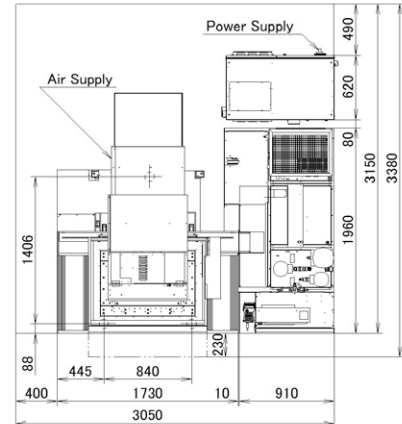
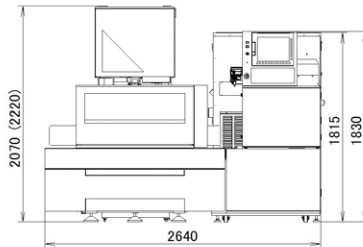

## α-C800iC

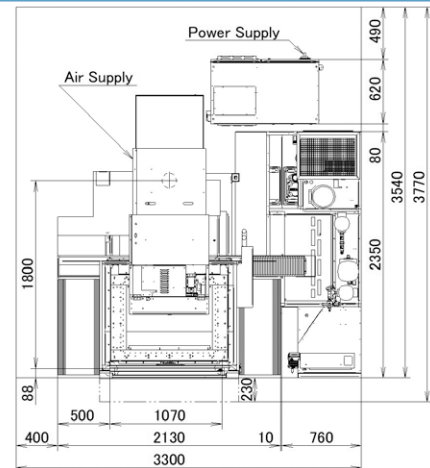
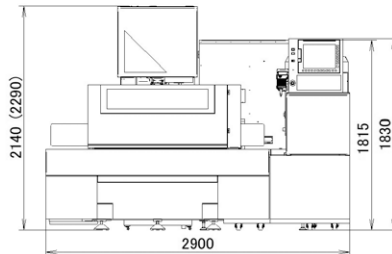

\* The values in parentheses ( ) are when the safety cover is open.

\* The above floor plan is that of a standard type machine. Contact FANUC if you wish to order the options such as a Z axis travel 410mm, 510mm and 30kg wire loader options.

# Installation Requirement

Power supply	200VAC±10% 3-phase 50/60Hz ±1Hz 220VAC±10% 3-phase 60Hz ±1Hz Connection cable terminal size : 8-5 Power consumption : 13kVA	Environment	Ambient temperature : 15 to 30°C *Recommend 20±1°C for high precision machining. Install under the oil mist free and dust free environment. Humidity : 75%RH or less
Air supply	Pressure : 0.5 to 0.7 MPa Flow rate : 160L/min or more *Regulator-side coupler mounting screw : Rc1/4	Grounding	400mm or more are recommended as concrete foundation ground where machine is located to endure its weight. Ground should be selected where no vibration or no impact effect. As vibration level, the maximum amplitude should be 2μm or less under frequency band from 10 to 20 Hz. The unit must be grounded to prevent damage resulting from electro-magnetic interference or electrical leakage. The unit is recommended to be installed so that the ground resistance is less than 10Ω. Also, the grounding should be isolated from other machines.
Shield room	If discharge noise can interfere with surrounding radio, television and other sets, a shield room needs to be created		



# Specifications

Model			$\alpha$ -C400iC	$\alpha$ -C600iC	$\alpha$ -C800iC
Maximum workpiece dimensions	without Automatic door	Z axis travel standard	730 x 630 x 250 mm	1050 x 820 x 300 mm	—
		Z axis travel option	—	1050 x 820 x 400 mm	—
	with Automatic door	Z axis travel standard	730 x 585 x 250 mm	1050 x 775 x 300 mm	1250 x 975 x 300 mm
		Z axis travel option	—	1050 x 775 x 400 mm	1250 x 975 x 500 mm
Maximum mass of workpiece			500 kg	1000 kg	3000 kg
XY axis table travel			400 x 300 mm	600 x 400 mm	800 x 600 mm
Z axis travel	standard		255 mm	310 mm	
	option		—	410 mm	510 mm
UV axis travel			$\pm 60$ mm x $\pm 60$ mm	$\pm 100$ mm x $\pm 100$ mm	
Maximum taper angle	standard		$\pm 30^\circ$ /80 mm	$\pm 30^\circ$ /150 mm	
	option		$\pm 45^\circ$ /40 mm	$\pm 45^\circ$ /70 mm	
Wire diameter	standard		$\phi 0.10$ to $\phi 0.30$ mm		
	option		$\phi 0.05$ to $\phi 0.30$ mm	—	
Maximum wire mass			16 kg		
Mass (including the dried work tank)			Approx. 2200 kg	Approx. 3600 kg	Approx. 5300 kg
Controller			<b>FANUC Series 31i-WB</b>		

Product  
introduction video



## FANUC CORPORATION

3580, Shibokusa, Oshino-mura, Minamitsuru-gun, Yamanashi, 401-0597, JAPAN

Phone: (+81)555-84-5555 <https://www.fanuc.co.jp/>

- All specifications are subject to change without notice.
- No part of this catalog may be reproduced in any form.
- The photo includes options.
- The products in this catalog are controlled based on Japan's "Foreign Exchange and Foreign Trade Law". The export of these products from Japan is subject to an export License by the government of Japan.  
Further, re-export to another country may be subject to the license of the government of the country from where the product is re-exported.  
Furthermore, the product may also be controlled by re-export regulations of the United States government.
- Should you wish to export or re-export these products, please contact FANUC for advice.

© FANUC CORPORATION, 2020  
RCUT-CiC(E)-04, 2024.3, Printed in Japan