

# FANUC Robot ARC Mate 100iD

# FANUC Robot ARC Mate 120iD

## FEATURES

FANUC Robot ARC Mate 100iD / 120iD is the cables integrated arc welding robot with an enhanced dress-out ability.

- The robot is available to meet a variety of operating spaces.
- The unique gear drive mechanism realizes the slim arm of the torch cable integrated robot.
- Welding cable utilities backside the wire feeder can be integrated in the enlarged J1 hollow tube. It makes system setup easy.
- Not only the torch cable but also the sensor cable can be integrated in the J3 arm due to the enlarged J4 and J6 hollow tubes. The wire feeder can be compactly mounted backside of the J3 arm.
- Higher rigidity of the arm provides high speed and high accuracy of the robot motion. It can enhance the productivity of the system.
- Off-line teaching by ROBOGUIDE (Option) reduces touch-up cost.
- Various intelligent functions with *i*RVision (integrated vision) and coordinated motion with the positioner are available.



## Application Examples



Automotive part welding



Stainless part welding

# Operating space

## ARC Mate 100iD/16S, 100iD, /10L, /8L

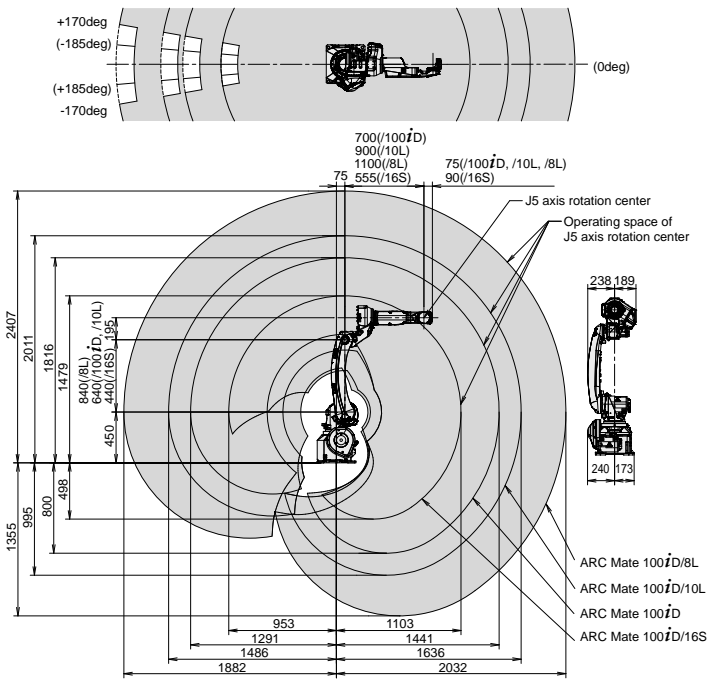

## ARC Mate 120iD, /35, /12L

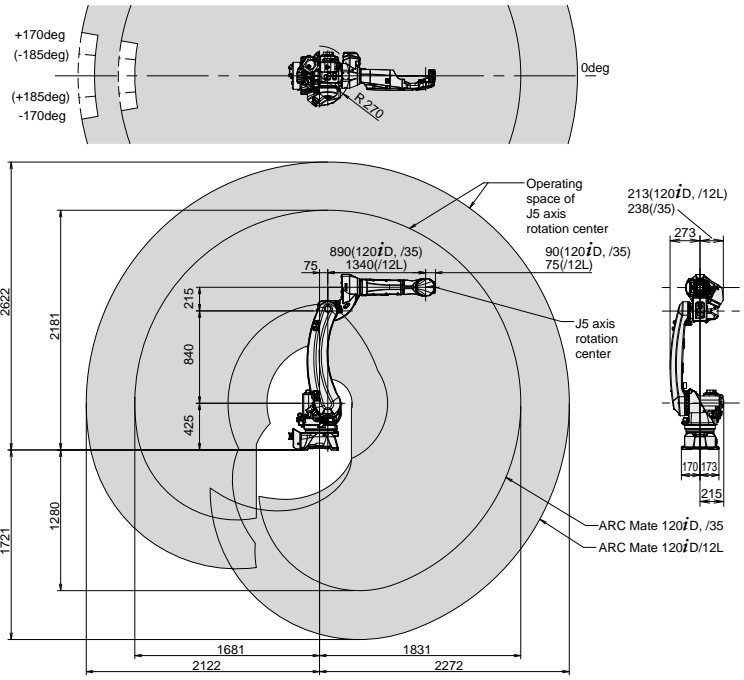

# Specifications

Model	ARC Mate 100iD/16S	ARC Mate 100iD	ARC Mate 100iD/10L	ARC Mate 100iD/8L	ARC Mate 120iD	ARC Mate 120iD/35	ARC Mate 120iD/12L
Type	6 axes (J1, J2, J3, J4, J5, J6)						
Reach	1103 mm	1441 mm	1636 mm	2032 mm	1831 mm	2272 mm	
Installation Note 1)	Floor, Upside-down, Angle mount						
Motion range (Maximum speed) Note 2), 3), 4)	J1 axis	370° (290°/s) 6.46 rad (5.06 rad/s)	370° (260°/s) 6.46 rad (4.54 rad/s)	370° (210°/s) 6.46 rad (3.67 rad/s)		370° (180°/s) 6.46 rad (3.14 rad/s)	370° (210°/s) 6.46 rad (3.67 rad/s)
	J2 axis	235° (270°/s) 4.10 rad (4.71 rad/s)	235° (240°/s) 4.10 rad (4.19 rad/s)	235° (210°/s) 4.10 rad (3.67 rad/s)	260° (210°/s) 4.54 rad (3.67 rad/s)	260° (180°/s) 4.54 rad (3.14 rad/s)	260° (210°/s) 4.54 rad (3.67 rad/s)
	J3 axis	455° (270°/s) 7.94 rad (4.71 rad/s)	455° (260°/s) 7.94 rad (4.54 rad/s)	455° (220°/s) 7.94 rad (3.84 rad/s)	458° (265°/s) 8.00 rad (4.63 rad/s)	458° (200°/s) 8.00 rad (3.49 rad/s)	458° (265°/s) 8.00 rad (4.63 rad/s)
	J4 axis	380° (430°/s) 6.63 rad (7.50 rad/s)			400° (420°/s) 6.98 rad (7.33 rad/s)	400° (350°/s) 6.98 rad (6.11 rad/s)	400° (420°/s) 6.98 rad (7.33 rad/s)
	J5 axis	360° (450°/s) 6.28 rad (7.85 rad/s)			360° (420°/s) 6.28 rad (7.33 rad/s)	360° (350°/s) 6.28 rad (6.11 rad/s)	360° (450°/s) 6.28 rad (7.85 rad/s)
	J6 axis	900° (730°/s) 15.71 rad (12.74 rad/s)	900° (720°/s) 15.71 rad (12.57 rad/s)			900° (400°/s) 15.71 rad (6.98 rad/s)	900° (720°/s) 15.71 rad (12.57 rad/s)
Max load capacity at wrist	16 kg	12 kg	10 kg	8 kg	25 kg	35 kg	12 kg
Allowable load moment at wrist	J4 axis	26.0 N·m	22.0 N·m	16.1 N·m	52.0 N·m	110.0 N·m	22.0 N·m
	J5 axis	26.0 N·m	22.0 N·m	16.1 N·m	52.0 N·m	110.0 N·m	22.0 N·m
	J6 axis	11.0 N·m	9.8 N·m	5.9 N·m	32.0 N·m	60.0 N·m	9.8 N·m
Allowable load inertia at wrist	J4 axis	0.90 kg·m <sup>2</sup>	0.65 kg·m <sup>2</sup>	0.63 kg·m <sup>2</sup>	2.40 kg·m <sup>2</sup>	4.00 kg·m <sup>2</sup>	0.65 kg·m <sup>2</sup>
	J5 axis	0.90 kg·m <sup>2</sup>	0.65 kg·m <sup>2</sup>	0.63 kg·m <sup>2</sup>	2.40 kg·m <sup>2</sup>	4.00 kg·m <sup>2</sup>	0.65 kg·m <sup>2</sup>
	J6 axis	0.30 kg·m <sup>2</sup>	0.17 kg·m <sup>2</sup>	0.061 kg·m <sup>2</sup>	1.20 kg·m <sup>2</sup>	1.50 kg·m <sup>2</sup>	0.17 kg·m <sup>2</sup>
Repeatability Note 5)	± 0.02 mm		± 0.03 mm		± 0.02 mm	± 0.03 mm	
Mass Note 6)	145 kg		150 kg	180 kg	250 kg		
Installation environment	Ambient temperature : 0 to 45°C						
	Ambient humidity : Normally 75%RH or less (No dew nor frost allowed), Short term 95%RH or less (within one month)						
	Vibration acceleration : 4.9m/s <sup>2</sup> (0.5G) or less						

Note 1) Angle mount is not supported for 4 brake type of ARC Mate 100iD.

Note 2) In case of equipping mechanical stopper, motion range of J1 axis is restricted to 340° (5.93 rad).

Note 3) In case of angle mounting, J1 and J2 axis motion range are restricted.

Note 4) During short distance motions, the axis speed may not reach the maximum value stated.

Note 5) Compliant with ISO9283.

Note 6) Without controller.

# FANUC CORPORATION

•Headquarters 3580, Shibokusa, Oshino-mura, Minamitsuru-gun Yamanashi, 401-0597, JAPAN  
Phone: (+81)555-84-5555 <https://www.fanuc.co.jp/>

- Overseas Affiliated Companies
- FANUC America Corporation
- FANUC Europe Corporation, S.A.
- SHANGHAI-FANUC Robotics CO., LTD.
- KOREA FANUC CORPORATION
- TAIWAN FANUC CORPORATION
- FANUC INDIA PRIVATE LIMITED
- FANUC SINGAPORE PTE. LTD.
- FANUC THAI LIMITED
- FANUC MECHATRONICS (MALAYSIA) SDN. BHD.
- PT. FANUC INDONESIA
- FANUC OCEANIA PTY. LIMITED
- FANUC SOUTH AFRICA (PROPRIETARY) LIMITED

Phone: (+1)248-377-7000  
Phone: (+352)727777-1  
Phone: (+86)21-5032-7700  
Phone: (+82)55-278-1200  
Phone: (+886)4-2359-0522  
Phone: (+91)80-2852-0057  
Phone: (+65)6567-8566  
Phone: (+66)2-714-6111  
Phone: (+60)3-3082-1222  
Phone: (+62)21-4584-7285  
Phone: (+61)2-8822-4600  
Phone: (+27)11-392-3610

<https://www.fanucamerica.com/>  
<https://www.fanuc.eu/>  
<https://www.shanghai-fanuc.com.cn/>  
<https://www.fkc.co.kr/>  
<https://www.fanuctaiwan.com.tw/>  
<https://www.fanucindia.com/>  
<https://www.fanuc.com/isp/>  
<https://www.fanuc.com/ftth/>  
<https://www.fanuc.com/fmm/>  
<https://www.fanuc.com/fin/>  
<https://www.fanucoceania.com.au/>  
<https://fanuc.co.za/>

- All specifications are subject to change without notice.
- No part of this catalog may be reproduced in any form.
- The products in this catalog are controlled based on Japan's "Foreign Exchange and Foreign Trade Law". The export from Japan may be subject to an export license by the government of Japan. Further, re-export to another country may be subject to the license of the government of the country from where the product is re-exported. Furthermore, the product may also be controlled by re-export regulations of the United States government. Should you wish to export or re-export these products, please contact FANUC for advice.

© FANUC CORPORATION, 2016

ARC Mate 100iD(E)-08a, 2022.4, Printed in Japan