

FANUC Robot P-40iA



FEATURES

- The FANUC P-40iA Robot is a mid-size paint robot with a 5kg payload capacity.
- It can be used in Zone 1 hazardous areas due to its high Equipment Protection Level Gb rating.
- The P-40iA's slim and compact body, small footprint and various mounting capabilities (floor, invert, angle mount) enables flexible layouts and a compact spray booth.
- The explosion protected purged motor box (option) simplifies the engineering of explosion protected robot peripherals such as rails or fixture rotators.
- Offline programming with FANUC's process focused PaintPro Software in ROBOGUIDE (option) drastically reduces programming time - saving time and engineering costs.

Application Example

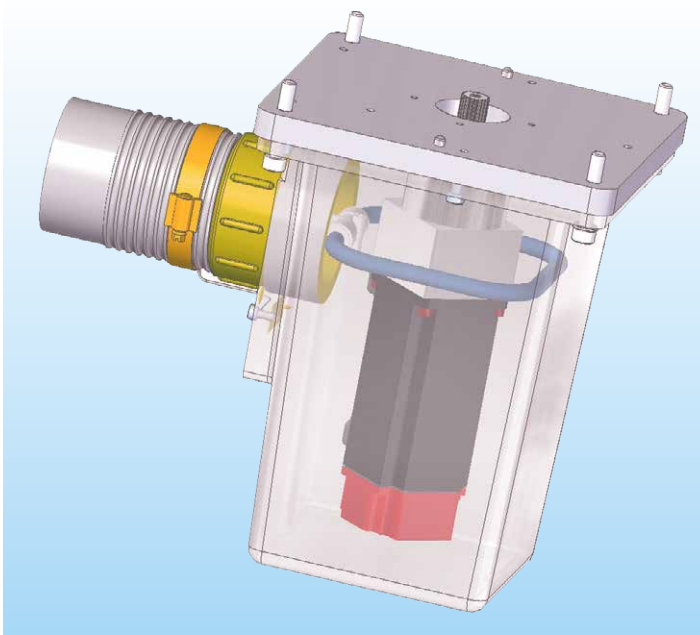

Explosion protected purged motor box (option)



Small part painting

Operating space

P-40iA

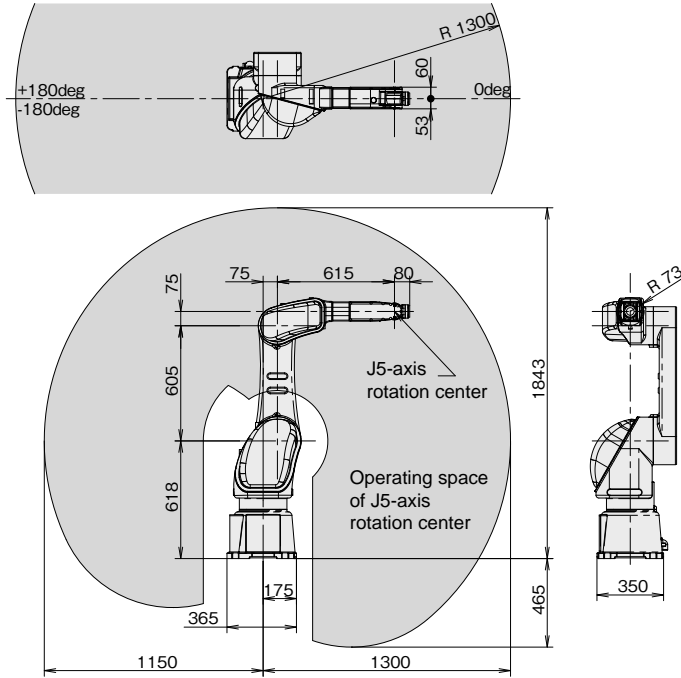

Specifications

Model		P-40iA	
Type		Articulated Type	
Controlled axes		6 axes (J1,J2,J3,J4,J5,J6)	
Reach		1300 mm	
Installation Note 1)		Floor, Upside-down, Wall, Angle mount	
Motion range (Maximum speed) Note 2)	J1 axis rotation	360° (220°/s)	6.28 rad (3.84 rad/s)
	J2 axis rotation	255° (190°/s)	4.45 rad (3.32 rad/s)
	J3 axis rotation	423° (240°/s)	7.38 rad (4.19 rad/s)
	J4 axis wrist rotation	380° (450°/s)	6.63 rad (7.85 rad/s)
	J5 axis wrist swing	240° (450°/s)	4.19 rad (7.85 rad/s)
	J6 axis wrist rotation	720° (720°/s)	12.57 rad (12.57 rad/s)
Max. load capacity at wrist		5 kg	
Max. load capacity on outer arm		1 kg	
Max. load capacity on inner arm		1 kg	
Allowable load moment at wrist	J4 axis	11.9 N·m	1.21 kgf·m
	J5 axis	11.9 N·m	1.21 kgf·m
	J6 axis	6.7 N·m	0.68 kgf·m
Allowable load inertia at wrist	J4 axis	0.3 kg·m ²	3.06 kgf·cm·s ²
	J5 axis	0.3 kg·m ²	3.06 kgf·cm·s ²
	J6 axis	0.1 kg·m ²	1.02 kgf·cm·s ²
Drive method		Electric servo drive by AC servo motor	
Repeatability		± 0.03 mm	
Mass Note 3)		110 kg	
Explosion protection rating		pxb ib IIB T4 Gb (Gas) (Japan) Class I, II, III Div. I Group C, D, E, F, G T4 (Gas, Dust) (US) II 2 G c Ex ib px IIB T4 Gb (Gas) (EU) II 2 D c Ex ib p IIIB T135°C Db (Dust) (EU)	
Installation environment		Ambient temperature : 0 – 45°C Ambient humidity : Normally 75 %RH or less (No dew, nor frost allowed) Short term Max. 95 %RH or less (within one month) Vibration acceleration : 4.9 m/s ² (0.5G) or less	

Note 1) Motion range is restricted in case of the wall or angle mounting.

Note 2) During short distance motions, the axis speed may not reach the maximum value stated.

Note 3) Without controller.

FANUC CORPORATION

- Overseas Affiliated Companies
- FANUC America Corporation
- FANUC Europe Corporation, S.A.
- SHANGHAI-FANUC Robotics CO., LTD.
- KOREA FANUC CORPORATION
- TAIWAN FANUC CORPORATION
- FANUC INDIA PRIVATE LIMITED
- FANUC SINGAPORE PTE. LTD.
- FANUC THAI LIMITED
- FANUC MECHATRONICS (MALAYSIA) SDN. BHD.
- PT. FANUC INDONESIA
- FANUC OCEANIA PTY. LIMITED
- FANUC SOUTH AFRICA (PROPRIETARY) LIMITED

Phone: (+1)248-377-7000
Phone: (+352)727777-1
Phone: (+86)21-5032-7700
Phone: (+82)55-278-1200
Phone: (+886)4-2359-0522
Phone: (+91)80-2852-0057
Phone: (+65)6567-8566
Phone: (+66)2-714-6111
Phone: (+60)3-3082-1222
Phone: (+62)21-4584-7285
Phone: (+61)2-8822-4600
Phone: (+27)11-392-3610

Headquarters 3580, Shibokusa, Oshino-mura, Minamitsuru-gun
Yamanashi, 401-0597, JAPAN
Phone: (+81)555-84-5555 <https://www.fanuc.co.jp/>

<https://www.fanucamerica.com/>
<https://www.fanuc.eu/>
<https://www.shanghai-fanuc.com.cn/>
<https://www.fkc.co.kr/>
<https://www.fanuctaiwan.com.tw/>
<https://www.fanucindia.com/>
<https://www.fanuc.com/fsp/>
<https://www.fanuc.com/ftb/>
<https://www.fanuc.com/fmm/>
<https://www.fanuc.com/fin/>
<https://www.fanucoceania.com.au/>
<https://fanuc.co.za/>

- All specifications are subject to change without notice.
- No part of this catalog may be reproduced in any form.
- The products in this catalog are controlled based on Japan's "Foreign Exchange and Foreign Trade Law". The export from Japan may be subject to an export license by the government of Japan. Further, re-export to another country may be subject to the license of the government of the country from where the product is re-exported. Furthermore, the product may also be controlled by re-export regulations of the United States government. Should you wish to export or re-export these products, please contact FANUC for advice.

© FANUC CORPORATION, 2019

RP-40iA(E)-01b, 2022.4, Printed in Japan