

FANUC Robot DR-3*i*B

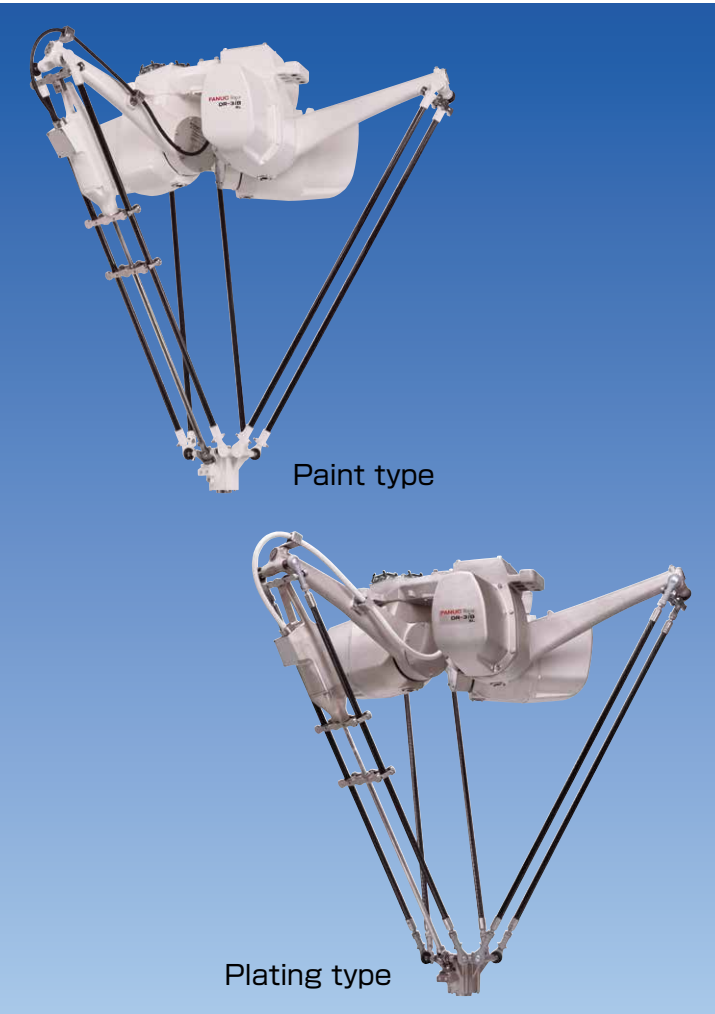

FEATURES

FANUC Robot DR-3*i*B/8L is a parallel link robot for high speed picking with 8kg payload. It has achieved superior hygiene and motion to the previous model.

- Shape, materials, surface treatment and lubricant are considered for food hygiene. It can contribute to the automation in the food, pharmaceutical and cosmetics market.
- Two types of surface treatment are available based on an application environment.
 - Paint type : Its chemical resistance is good for secondary food
 - Plating type : No paint on its surface is good for primary food
- This is a 4 axes robot including a single axis rotation at wrist. It has 8kg maximum payload and 0.2kgm² maximum inertia and it has increased the speed by 10% compared with the previous model. It is suitable for high speed aligning and handling of multiple pieces on conveyor.
- By expanding the operating space to 1600mm, it can be applied to a handling system with a wide conveyor.
- The enclosed mechanical unit can realize IP69K.
- Various intelligent functions are available, such as *i*RVision (integrated vision) and *i*RPickTool.

Application Examples

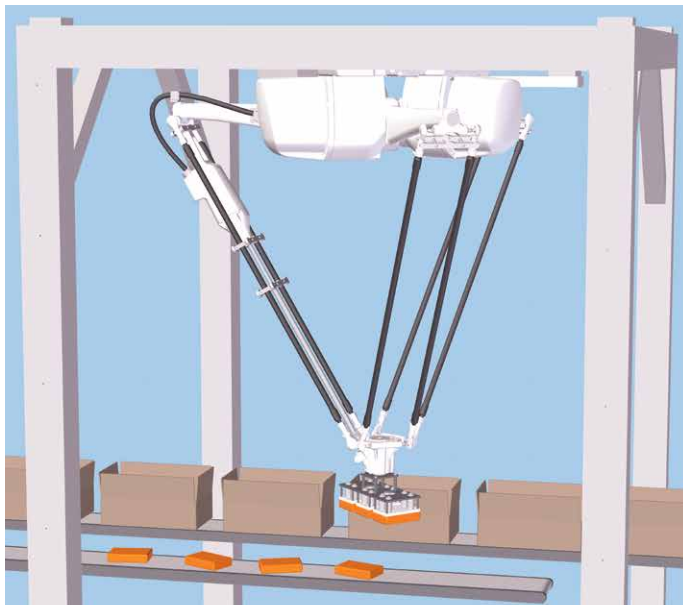

Fast packing of food by DR-3*i*B/8L

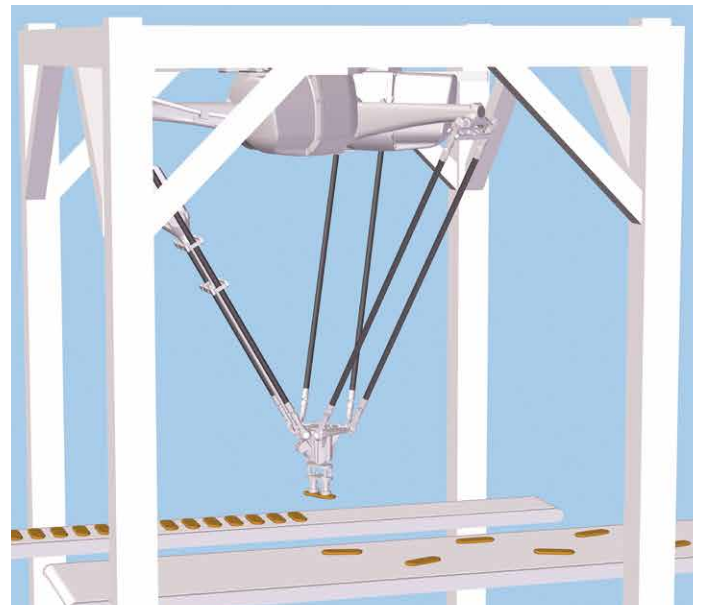

Fast arranging of food by DR-3*i*B/8L

DR-3iB/8L

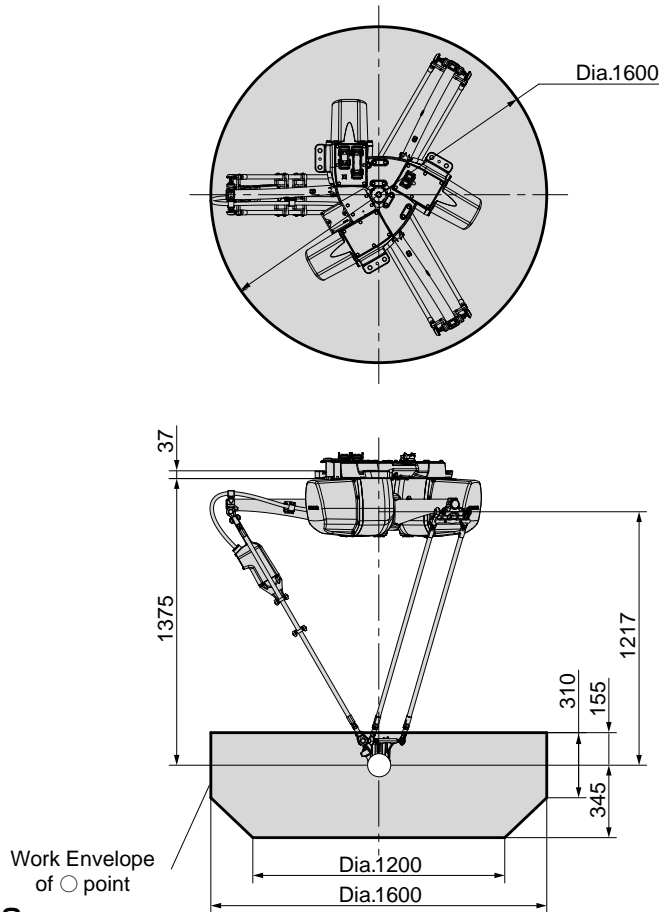

Specifications

Model		DR-3iB/8L	
Type		Parallel link mechanism	
Controlled axes		4 axes (J1,J2,J3,J4)	
Installation		Ceiling mount	
Motion range	J1-J3	Diameter 1600mm, height 500mm	
(Maximum speed) Note 1)	J4	720° (2000°/s) 12.57rad (34.91rad/s)	
Max.payload at wrist		8 kg	
Repeatability Note 2)		±0.03mm	
Drive method		Electric servo drive by AC servo motor	
Mass Note 3)		170kg	
Installation environment		Ambient temperature : 0 to 45°C Ambient humidity Normally : 75%RH or less (No dew, nor frost allowed) Short term : 95%RH or less (within one month) Vibration : 4.9m/s ² (0.5G) or less	

Note 1) During short distance motions, the axis speed may not reach the maximum value stated.

Note 2) Compliant with ISO9283.

Note 3) Without controller.

FANUC CORPORATION

- Overseas Affiliated Companies
- FANUC America Corporation
- FANUC Europe Corporation, S.A.
- SHANGHAI-FANUC Robotics CO., LTD.
- KOREA FANUC CORPORATION
- TAIWAN FANUC CORPORATION
- FANUC INDIA PRIVATE LIMITED
- FANUC SINGAPORE PTE. LTD.
- FANUC THAI LIMITED
- FANUC MECHATRONICS (MALAYSIA) SDN. BHD.
- PT. FANUC INDONESIA
- FANUC OCEANIA PTY. LIMITED
- FANUC SOUTH AFRICA (PROPRIETARY) LIMITED

- Phone: (+1)248-377-7000
- Phone: (+352)727777-1
- Phone: (+86)21-5032-7700
- Phone: (+82)55-278-1200
- Phone: (+886)4-2359-0522
- Phone: (+91)80-2852-0057
- Phone: (+65)6567-8566
- Phone: (+66)2-714-6111
- Phone: (+60)3-3082-1222
- Phone: (+62)21-4584-7285
- Phone: (+61)2-8822-4600
- Phone: (+27)11-392-3610

- Headquarters 3580, Shibokusa, Oshino-mura, Minamitsuru-gun Yamanashi, 401-0597, JAPAN
- Phone: (+81)555-84-5555 <https://www.fanuc.co.jp/>

- <https://www.fanucamerica.com/>
- <https://www.fanuc.eu/>
- <https://www.shanghai-fanuc.com.cn/>
- <https://www.fkc.co.kr/>
- <https://www.fanuctaiwan.com.tw/>
- <https://www.fanucindia.com/>
- <https://www.fanuc.com/isp/>
- <https://www.fanuc.com/ftth/>
- <https://www.fanuc.com/fmm/>
- <https://www.fanuc.com/fin/>
- <https://www.fanucoceania.com.au/>
- <https://fanuc.co.za/>

- All specifications are subject to change without notice.
- No part of this catalog may be reproduced in any form.
- The products in this catalog are controlled based on Japan's "Foreign Exchange and Foreign Trade Law". The export from Japan may be subject to an export license by the government of Japan. Further, re-export to another country may be subject to the license of the government of the country from where the product is re-exported. Furthermore, the product may also be controlled by re-export regulations of the United States government. Should you wish to export or re-export these products, please contact FANUC for advice.