

Standard CNC with enhanced basic performance and productivity

FANUC

Series 0i-MODEL F Plus



FANUC's New Standard CNC

FANUC Series 0i-MODEL F Plus

More powerful and easier to use

- Improved visibility and operability with renewal design of screen
- Equipped with *i*HMI for consistent support at shop floor
- Equipped with FANUC's latest CNC and Servo technologies
- Customizable functions for characteristic screens and operation as standard
- Extended memory capacity for storing large sized program
- Easy robots connection and control



Maximizing Uptime

- Prevent sudden machine downtime with preventive maintenance
 - ▶ Extensive failure prediction functions
- Reduce recovery time by easily pinpointing faulty parts
 - ▶ Diagnosis/maintenance functions

Machining Performance

- Improved productivity through reduced cycle times
 - ▶ Fast Cycle-time Technology
- Achieves high-quality machining
 - ▶ Fine Surface Technology



Two-product line-up covering different purposes

CNC for Machining Center

FANUC Series 0i-MF Plus

- 1-path system total controllable axes: up to 18
- 2-path system total controllable axes: up to 18
- Simultaneous controlled axes : up to 4 axes

CNC for Lathe

FANUC Series 0i-TF Plus

- 1-path system total controllable axes: up to 18
- 2-path system total controllable axes: up to 18
- Simultaneous controlled axes : up to 4 axes

(Total controllable axes: total of feed axes, spindles and peripheral axes)



Ease of Use

- Consistent support at shop floor
 - ▶ FANUC *i*HMI
- Original screen for ease of use
 - ▶ Comes standard with customizable functions
- IoT integration
 - ▶ Extensive compatibility with field networks

System configuration

CNC control unit (LCD mounted type/stand-alone type)

Line-up of displays that are compatible with the various types of machine tools, from compact to large and standard to high-spec, such as the FANUC *i*PC, PANEL *i*H compatible with *i*HMI and the compact 10.4" LCD/MDI unit.



FANUC *i*PC
24" / 21.5" / 18.5" / 15" / 10.4"



PANEL *i*H/*i*H Pro Standard display Standard display Handheld unit
15"/10.4" LCD 15" LCD 10.4" LCD/MDI

Handheld unit

Equipped with an emergency stop button and a manual pulse generator, this handy unit line-up achieves safe manual operation of machine tools.



*i*Pendant Handy Machine Operator's Panel Portable manual pulse generator

I/O Unit

Wide range of I/O units compatible with various installation locations and I/O devices.

Optimized for operator's panels with its thin and space-saving design

Standard operator's panel with key input duplication Handles the output/input of safety signals Compatible with original operator's panels



Safety Machine operator's panel I/O module for operator's panel supporting safety function I/O module for operator's panel

Optimized for control cabinets with high scalability and extensive modules such as the multi-point output/input type and the analog/digital output/input module

Small size I/O unit with improved expandability, workability and maintainability Excellent performance multi-point out cost with put/input Compact and with reduced wiring Effective for thermal displacement compensation with multi-point temperature sensor input



FANUC Slice I/O I/O unit for magnetics power cabinet I/O unit for connector panel Temperature sensor input unit

Optimized for reduced wiring by enabling distributed setup

Can be positioned near sensors scattered inside and outside the machine cabinet



I/O Unit-MODEL B

Ethernet

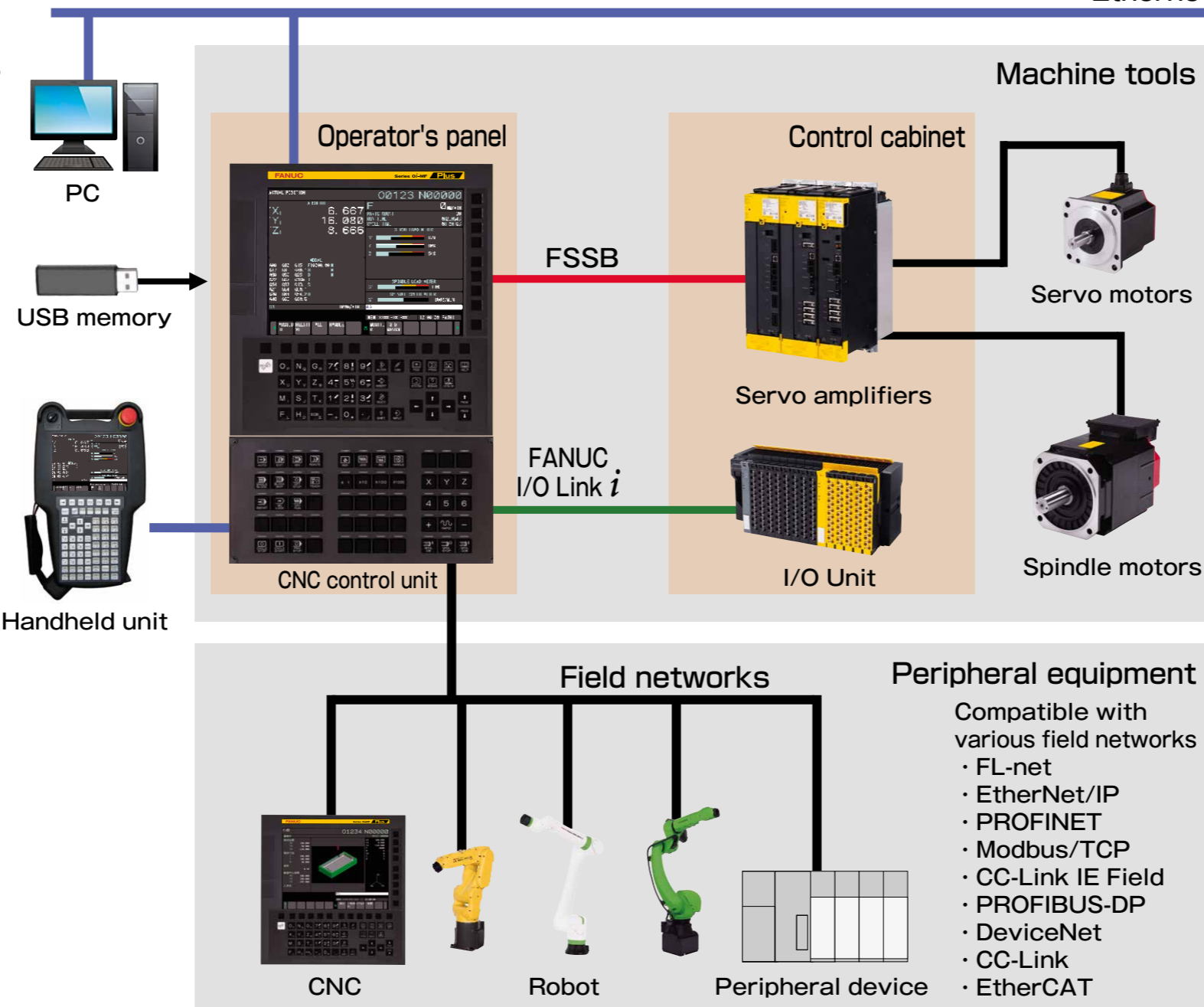

Servo motor

Line-up to meet the various needs of machine tools and contribute to the performance improvement of feed axes



SERVO MOTOR *ai*-D series DD MOTOR *Di*S-B series LINEAR MOTOR *Li*S-B series

Spindle motor

Line-up to meet the various needs of machine tools and contribute to the performance improvement of spindles



SPINDLE MOTOR *ai*-D series BUILT-IN SPINDLE MOTOR *Bi*-B series

Servo amplifier

Line-up to be flexibly available for a variety of machine tools and contribute to the downsizing of cabinets



SERVO AMPLIFIER *ai*-D series

Fast Cycle-time Technology

Fast Cycle Time Technology refers to CNC and servo technologies that achieve reduced cycle times. It reduces cycle times of machining programs through methods such as accelerating and decelerating depending on the operational state, making the best use of spindle performance, and reducing the sequence processing time for external signals.

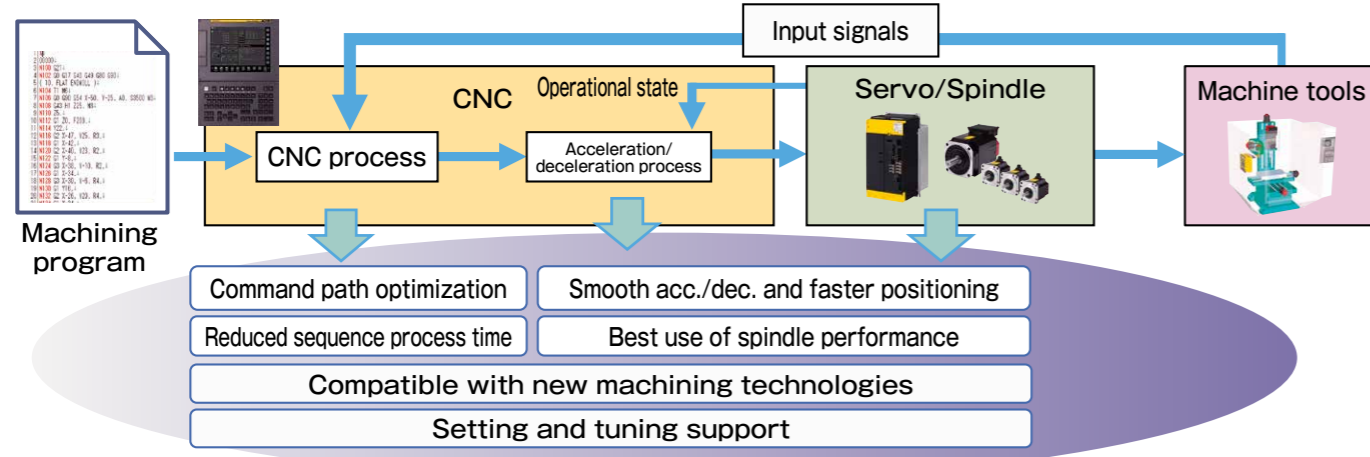

Fast Cycle-time setting

Easily reduce cycle times

The Fast Cycle-time setting compares the currently set parameter setting to the FANUC default setting, allowing you to easily use the setting that most effectively reduces cycle time.



Reduced cycle time example: Workpiece for evaluation

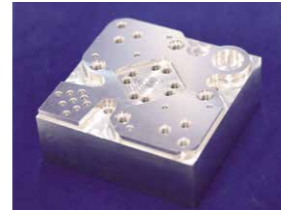

Before application 4 minutes 47 seconds → After application 4 minutes 4 seconds
Approx. 15% reduction

Smart Servo Control

Smart Servo Control is a group of functions to optimize control in real time according to the change of machine conditions such as load and temperature. These functions contribute to high-speed, high-precision and high-quality machining as the control technology supporting Fast Cycle-time Technology and Fine Surface Technology.

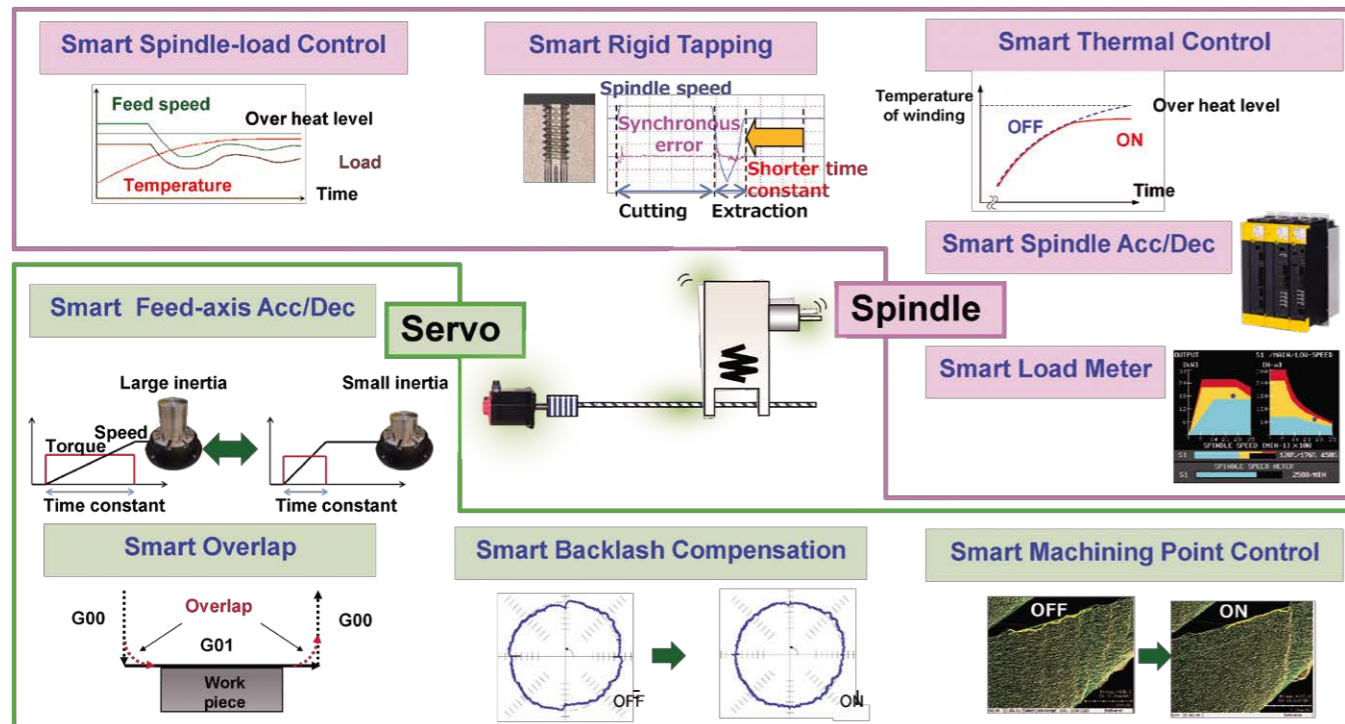

Fine Surface Technology

Fine Surface Technology is a collective term for CNC and servo technologies that achieve fine surface machining. This technology allows for the interpolation of high precision machining program output from CAD/CAM, high-speed execution of small segment programs, the generation of a smooth tool path and accurate command follow-up. These tasks more efficiently by taking digital technology.

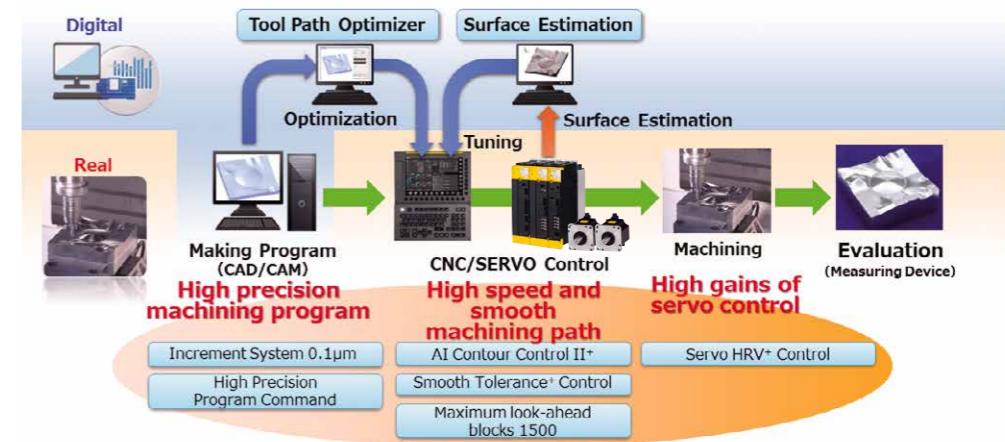

Fine Surface settings

Standard setting values are provided based on machining conditions (roughing, semi-finishing, or finishing), and slide bars can be intuitively used to set and adjust high-speed, high-precision machining parameters based on the machine. Machining under optimal conditions can be achieved by selecting machining processes during the machining itself using a machining program or screen operations.

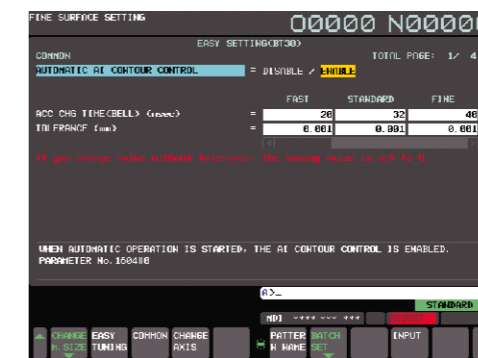

Smooth Tolerance+ Control

Smoothing continuous small blocks to realize fine surface machining

The machining path specified in continuous small blocks, like the one for mold machining, is smoothed out within the specified allowance error tolerance. The smooth machining path reduces mechanical shock and improves the quality of the machined surface.

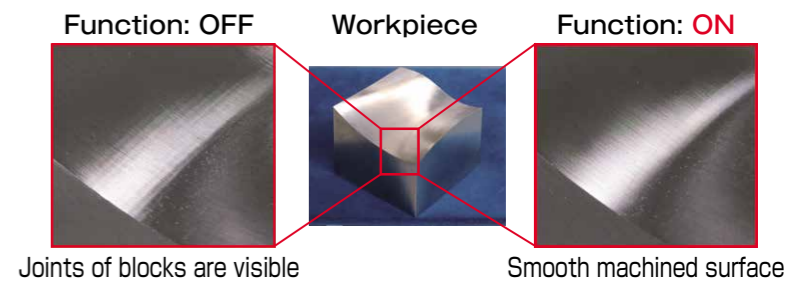

Servo Learning Oscillation

Servo learning oscillation that applies servo learning control also accurately tracks oscillation commands with a high frequency, thereby achieving dependable chip shredding. It can be applied to turning, drilling and threading.

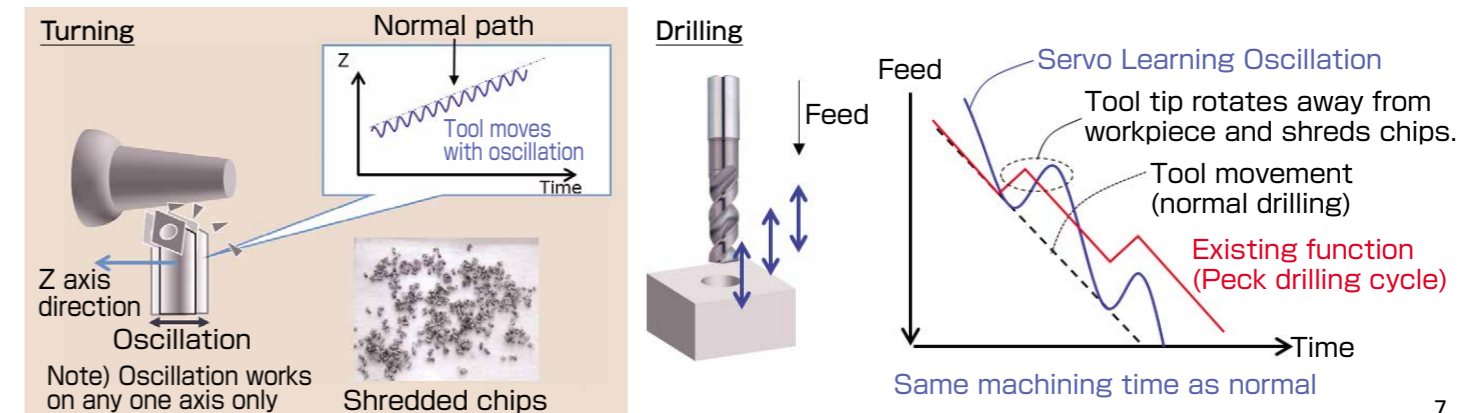

Excellent control function

Machining Performance

Smooth TCP

Simultaneous 4-axis machining including the rotation axis is available with the program that specified tool center point path.

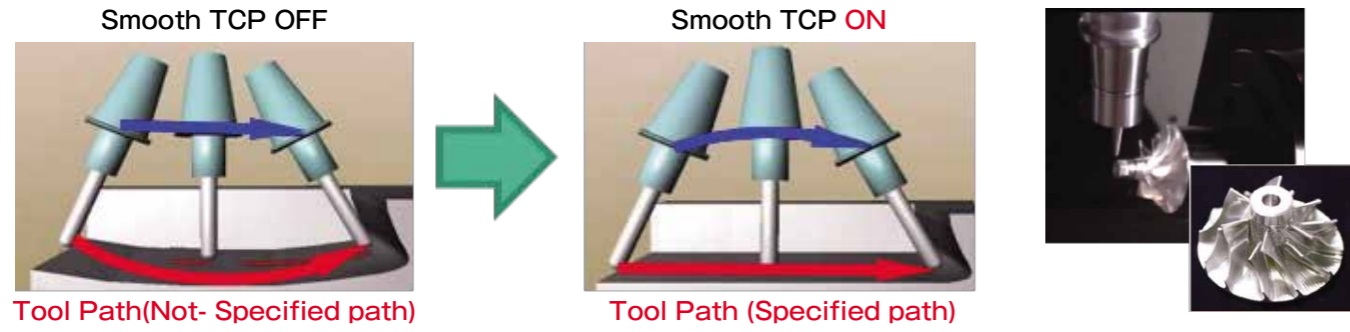

Tool center point path follows specified path with high accuracy interpolation. This function can achieve smooth machining of complicated shapes including undercuts like an impeller that cannot be machined with 3 axes. Tool offset and kinematic conversion applied to a rotary axis are executed by CNC. So that, a machine configuration is not needed to consider on the CAM side, and improves affinity with CAD/CAM.

AI Thermal Displacement Compensation

Using data that relates multiple machine temperature points to machining-point displacement, a machine-learning-based thermal displacement model predicts and compensates for thermal deformation. This enables stable high-accuracy machining, reduces warm-up time, and relaxes factory temperature control, helping lower power consumption and environmental impact. The model is automatically generated by a dedicated model-development tool, which detects abnormalities in the collected data and supports the creation of highly accurate and reliable compensation models.

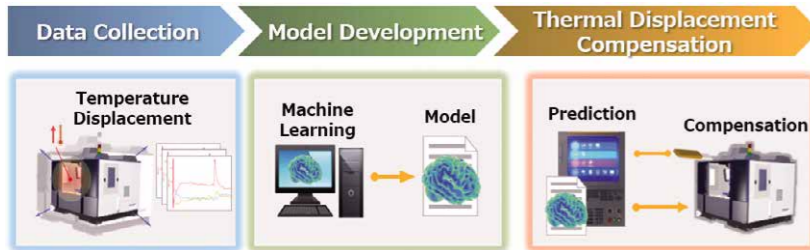

Workflow of AI Thermal Displacement Compensation



Reduction of Warm-Up Time

It also compensates for ball screw thermal displacement, enabling accurate positioning normally achieved with linear scale feedback, without using a linear scale. The thermal displacement model is automatically generated by the dedicated development tool, and the CNC uses it to predict and compensate for ball screw thermal displacement based on feed-axis motion and ambient temperature. This improves machining accuracy not only at the machining point but over the entire machining area.

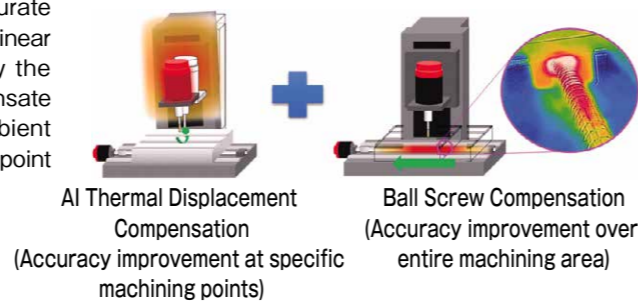

Excellent Operability

Ease of Use

Utilization of USB Memory

Load & Go function

- Program on USB memory can be operated easily by Load & Go function.
- Copy from USB memory & Selection to main program is completed with one touch.

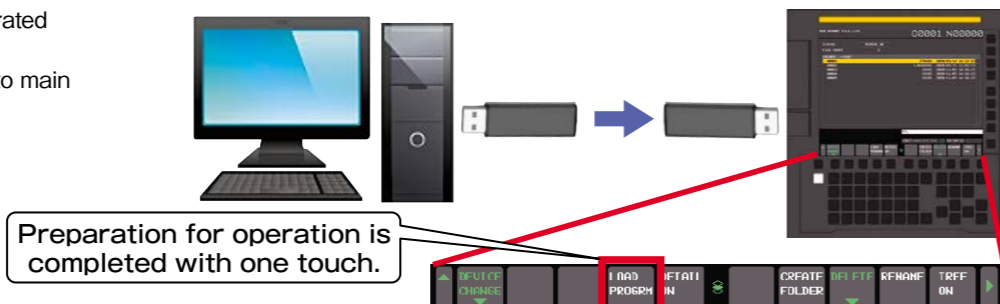

Excellent Operability

Ease of Use

Intuitive operation and reduced operation steps by touch

The 10.4" LCD/MDI unit with a touch panel reduces the operation steps and enables intuitive screen operation by touch.

- Touch operations such as cursor movement by tapping and page switching by flicking are supported.
- Operations that require multiple key presses can be completed with a single tap.
- Supports features such as Back and Forward navigation to quickly access the desired screen.
- C Language Executor also supports touch operations, enabling the creation of intuitive, touch-based customized screens.
- The unit is equipped with a high-reliability touch panel that is resistant to coolant and electrical noise, significantly reducing the risk of unintended operation and ensuring stable operation even in harsh environments. It also supports glove operation.



Consistent Support at Shop Floor

Ease of Use

FANUC iHMI

FANUC iHMI supports all jobs at shop floor consistently, exceeding a limit of conventional CNC operation. For the flow of "planning," "machining," and "improvement," process, various functions such as tool data registration, machining time prediction, programming, and post-machining inspection has been provided. Any of them can be easily operated by intuitive operability. In addition, at the center of each function is the home screen, which can be displayed from any screen with a dedicated key, so there is a sense of security that you can return at any time.



CNC operation

The CNC operation screen has been consolidated into three screens, "programming", "setup", and "machining", which reduces screen switching operations and greatly improves operability. In the CNC operation screen, machining programs can be easily recognized and easily created, such as color-coded display for each command and comment input function for tool information.

- G-code Guidance enables easy programming with machining selection and input screen even if complex command. It reduces program creation time and errors.
- Machining program preview detects programming errors before machining. It reduces working time and costs.
- The help, troubleshooting, and other functions are available to solve problems at a time if you have difficulty.



HOME screen



CNC operation screen

Tool manager

- Tool data of each application of FANUC iHMI can be centrally managed and all the tool data can be referred here.
- By reading the catalog data provided by tool makers, such as mold model number, dimensions, and machining conditions of the tool, the time to enter the tool data can be reduced.

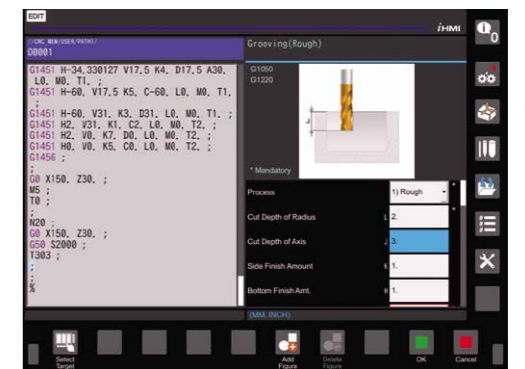

G-code Guidance

Many Customizable Functions

Ease of Use

Customizable functions are available, which allow machine tool builders to customize their own machine tools

Customizing operation screens

FANUC PICTURE

This tool enables you to create a machine operation screen simply by pasting screen components such as buttons and lamps on the PC.

- The screen creation tool is FANUC's proprietary easy-to-use user interface that is optimized for creating screens for CNCs.
- Screens that are created can be displayed and operated on various CNC models.
- Complicated controls such as network communication and file control can be easily implemented by using general-purpose scripts.

In addition, in PANEL *iH/iH* Pro and FANUC *iPC*, it is possible to create screens that leverage the performance of display devices.

- You can display the font for each language of any desired size.
- You can display buttons, lamps, and high precision images in full color.

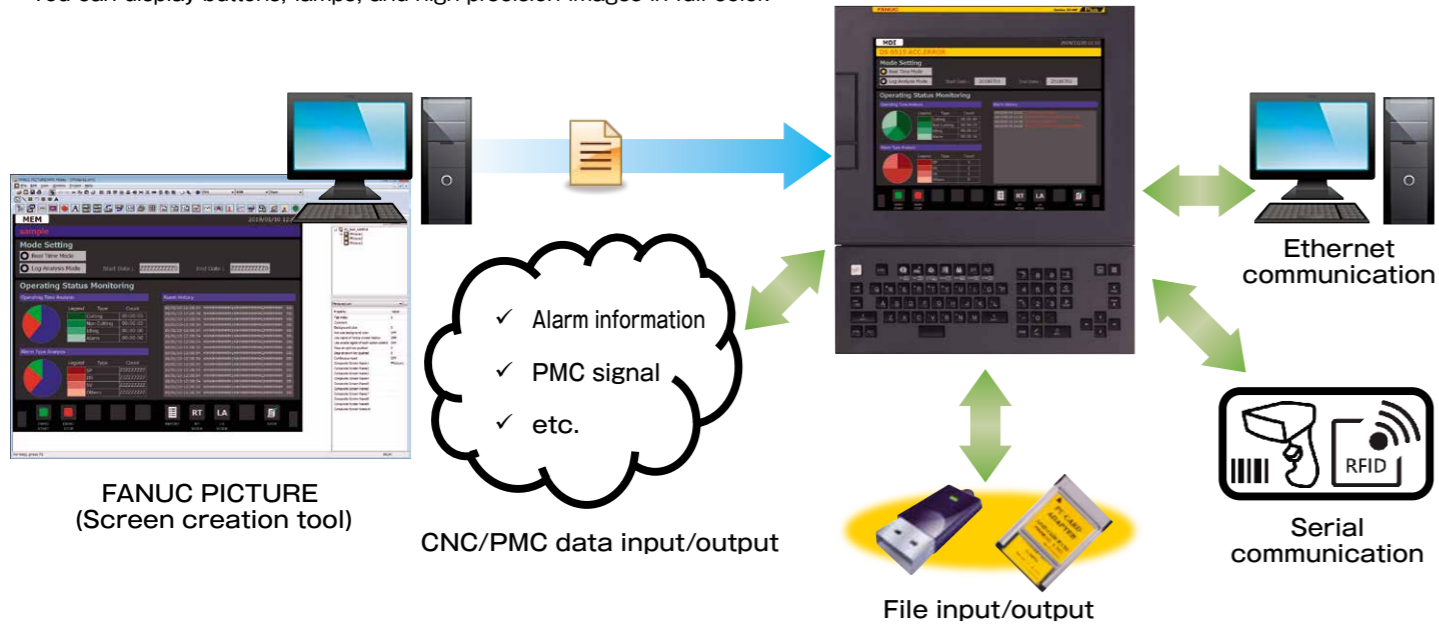

C Language Executor

Machine tool builders can create their own operation screens, which enables unique CNC display and operation.

- C language is used for programming.
- Multi window display enables creation of pop-up menus.
- Operation screens using the touch panel can be created. On the 10.4" LCD/MDI unit with a touch panel, screens utilizing operations such as swiping and flicking can also be created.
- In addition to standard ANSI functions, many functions are available for CNCs and PMCs.
- High-level tasks to which high execution priority is assigned can monitor signal and position information.

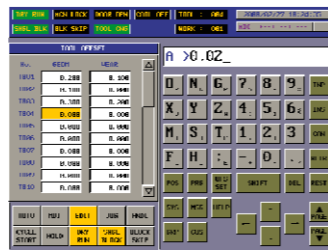

Implementing original sequence control based on PMC

FANUC LADDER-III

For machine customization, a machine tool builder's own sequence control can be incorporated into the built-in PMC. A PMC sequence program can be created on a personal computer by using FANUC LADDER-III, a very easy-to-use programming tool with many useful functions.

- A program can be created with ladder and function block.
- A program can be coded using signal names instead of signal addresses.
- Online monitoring and editing can be performed by connecting a personal computer with the CNC via Ethernet.
- Including PMC Function Library which enables you to integrate functions such as PMC axis control easily.

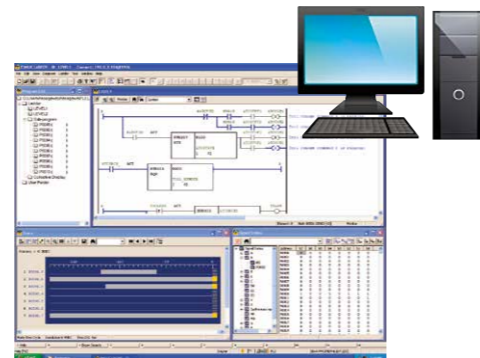

Pursuing Ease of Use

Ease of Use

Set-up Guidance Function

Measurement is achieved by touching the tool to the workpiece manually. And the measurement value can be set to the workpiece coordinate system. As a result, the arrangements time can be greatly reduced.

- Single surface measurement
- Outside diameter measurement
- Inside diameter measurement
- Outside width measurement
- Inside width measurement
- Measurement of corner outside
- Measurement of corner inside
- Angled workpiece measurement



Support for adding sensors and device

Multi C Language Executor

New custom screens can be easily added to the custom screens implemented in the machine (created with FANUC PICTURE or C language Executor).

Ladder Dividing Management Function

Ladders for controlling sensor or device can be added without changing the ladder for machinery control already implemented in the machine.

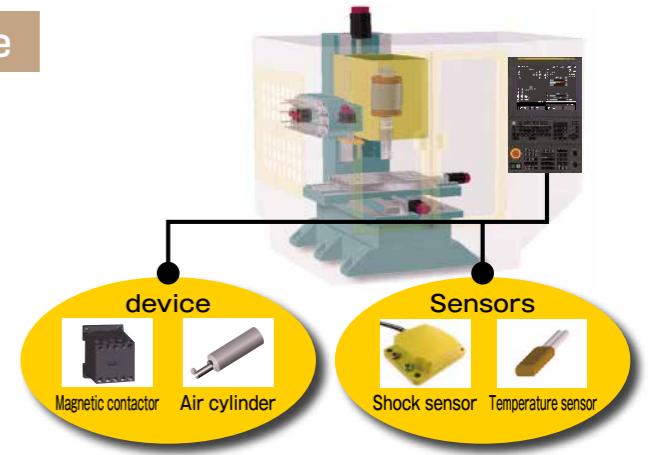

Easy Robots Connection and Control

Ease of Use

Integration of Robots to Machine Tools

This function allows you to easily connect a FANUC robot to a machine tool. Machine users with no experience using robots will be able to use robots easily.

Robot G-CODE

Robots can be operated with the feel of a machine tool.

- Utilize robots as part of machine tools with CNC programs (G code commands)
- By using familiar machine tool handles, robots can be positioned and taught easily from CNC screen



Robot ON-SITE

Robots can be installed on existing machines without changing machine tool system modification.

- Easy connection of CNC and robot via Ethernet cable without additional hardware
- Robot operation by using macro variables without ladder change

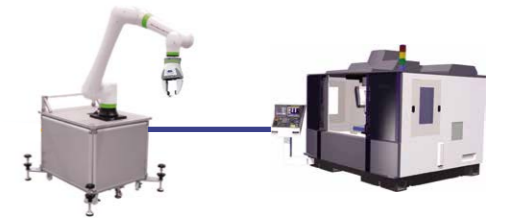

Network Support Functions

Ease of Use

Advancing the IoT adaptability of CNC machine tools with extensive network functions

Ethernet / Industrial Ethernet / Field Network

You can use Embedded Ethernet provided as standard and Fast Ethernet with a communication dedicated processor for NC program transfer and remote maintenance. Various types of Industrial Ethernet and Field Networks are supported to enable various types of peripheral devices to be connected for controlling peripheral devices such as waterproof I/O devices and collecting sensor information. Via a MULTI SENSOR I/O UNIT or other devices, information of impact, temperature, and other sensors can also be read.

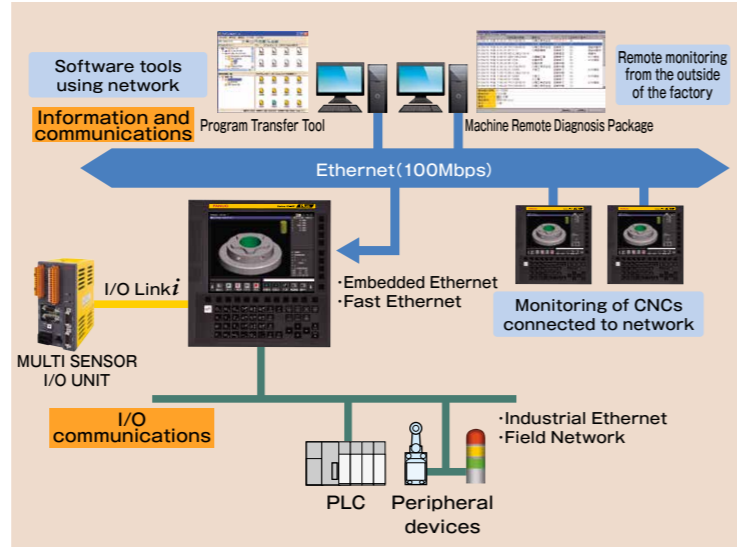

Supported Industrial Ethernet/Field Networks

- FL-net
- EtherNet/IP (Scanner/Adapter)
- PROFINET (IO Controller/IO Device)
- Modbus/TCP (Server)
- EtherCAT (Main Device)
- CC-Link IE Field (Device)
- PROFIBUS-DP (Master/Device)
- DeviceNet (Controller/Device)
- CC-Link (Device)

FIELD system Basic Package (Factory Data Platform)

Use & leverage factory equipment data

FIELD system Basic Package connects factory equipment through the network, turning hard-to-see on-site conditions into usable data and providing an all-in-one platform for solving operational issues. By analyzing data collected from factory equipment, it supports productivity gains, predictive maintenance, and other initiatives for building a smart factory.

- Connects to FANUC CNC machine tools in about five minutes.
- Connects to FANUC robots, OPC UA / MTConnect compatible CNC machines, and Modbus TCP PLCs.
- Collected data is stored in a unified format, enabling use regardless of equipment manufacturer.

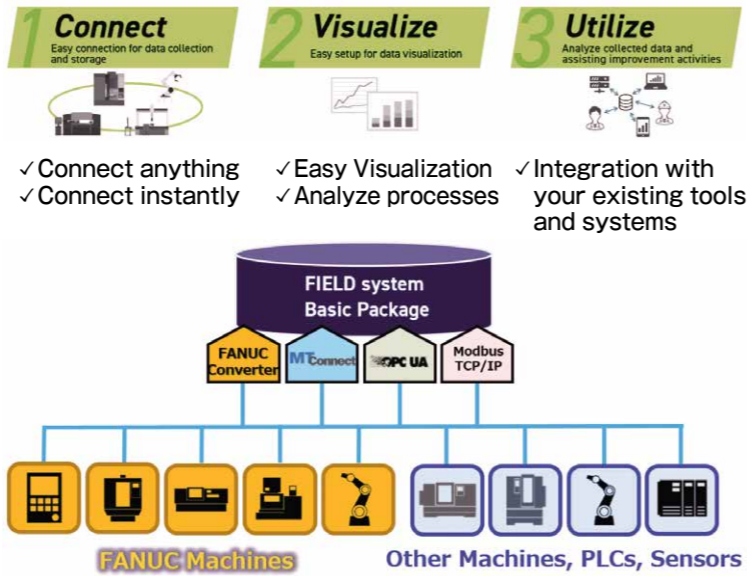

Visualizing equipment operation

With FIELD system Basic Package's Factory Visualizer, you can visualize the operating status of factory equipment.

- Visualize factory operating status with the overall equipment monitoring screen
- Check individual equipment status with the equipment history screen
- Manage production progress with the dashboard view
- Integrate with CNC machine status monitoring (Visual Assist)



Powerful PMC

Ease of Use

High-Speed, Large Capacity, and Multi-path PMC

High-Speed and Large Capacity

The integrated PMC now achieves even higher speeds. Large-scale sequence controls can be processed at high-speed using the powerful dedicated processor and the latest custom LSI.

- Program capacity Max. 100,000 steps (Total of all PMC paths)
- Internal relay (R) Max. 60,000 bytes
- Data table (D) Max. 60,000 bytes
- PMC paths Max. 3 paths (Max. 16 ladder programs)

Multi-path PMC

One PMC can execute up to three independent ladder programs, including loader control and peripheral equipment control.

- Ladder programs can easily be developed according to each user's machine configuration.
- Cost reductions are achieved by eliminating external PLCs or other devices for peripheral equipment control.

Function Block function

- This function enables repeated ladder circuit patterns to be arranged in function blocks and easily reused.
- The PMC function libraries attached to FANUC LADDER-III include functions ready for immediate embedding such as PMC axis and peripheral equipment control, and can be freely customized.

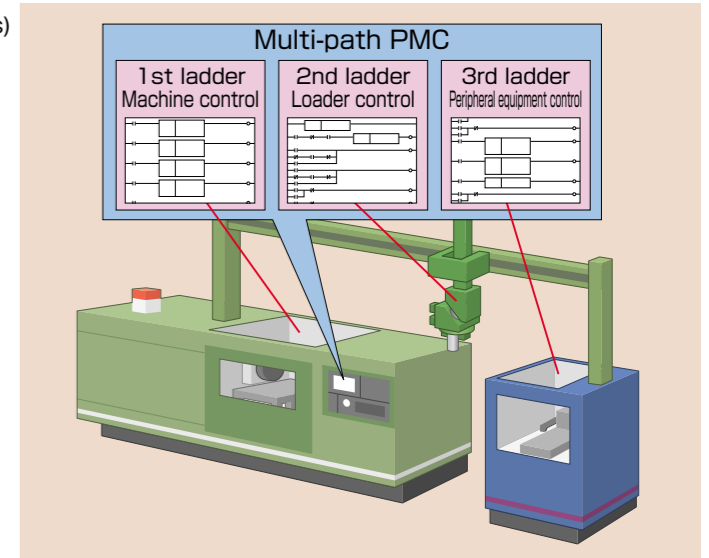

Reuse ladder circuits as function blocks

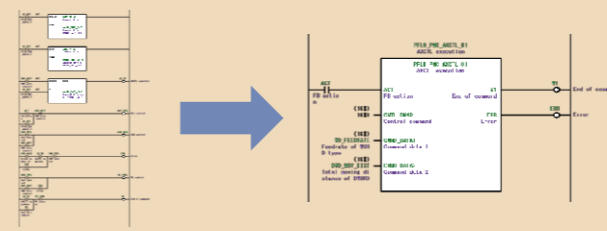

A full range of libraries are included in FANUC LADDER-III

- PMC axis control
- Operator's panel
- Spindle functions
- I/O devices
- CNC functions
- Others

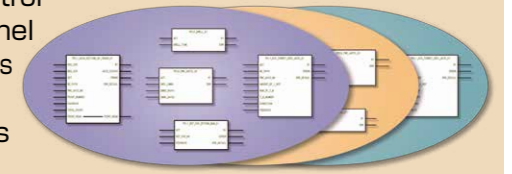

Safety functions

Ease of Use

Improvement of the safety of machine tool and machining line

Dual Check Safety Function

This is a safety function integrated into the CNC that conforms to ISO 13849-1 PL d. Multiple processors perform dual monitoring of the actual positions, speed, and safety-related I/O of servo motors and spindle motors, securing a high level of safety by providing duplicated paths for cutting off power.

Network safety function

By combining this function with the Dual Check Safety function, safety functionality of the machining line is achieved.

- Safety function by FL-net
- EtherNet/IP Adapter Safety function
- PROFINET IO Device Safety function
- PROFINET IO Controller Safety function

Safe Torque Off (STO) function

This is a safety function integrated in servo amplifiers that conforms to IEC 61800-5-2. Motor power can be safely cut off by the duplicated cut-off path within the amplifier.

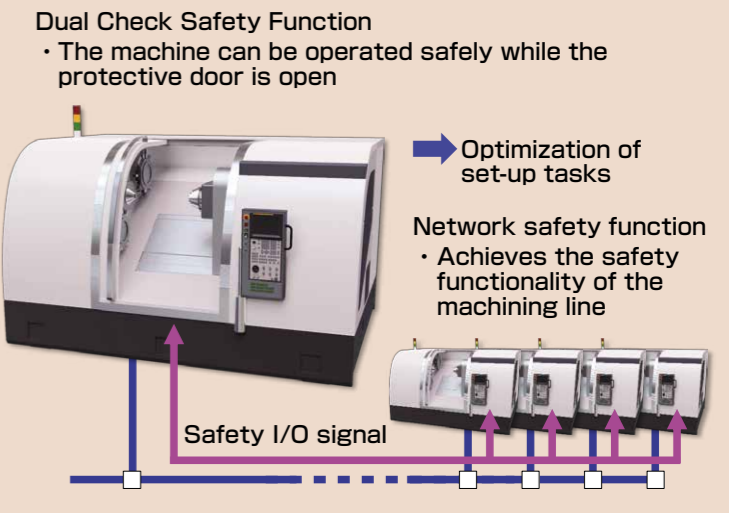

Easy Maintenance

Maximizing Uptime

Functions for maximizing uptime

Contribution to Preventive Maintenance

Cooling Fan Warning Function

By monitoring a decrease in the rotational speed of each cooling fan motor of the CNC and the servo amplifier, signs of fan abnormalities can be detected. This function enables preventive maintenance. Fans are stored in a cartridge and can be replaced quite easily, so maintainability is enhanced.

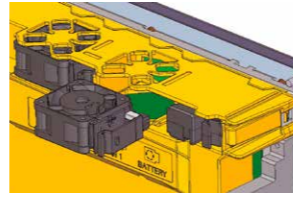

Failure Part Detection

Trouble Diagnosis Function

Various failure detection functions provided to the I/O Link *i* and FSSB can detect interruptions in the power supply to the I/O modules or servo amplifier and identify disconnection locations of the communication cable. In addition to that, I/O Link *i* can detect the ground fault of each DO.

The trouble diagnosis function enables you to see diagnosis information helpful in determining the status when an alarm occurs on the CNC screen.

- Trouble diagnosis guidance screen
- Trouble diagnosis monitor screen
- Trouble diagnosis graph screen

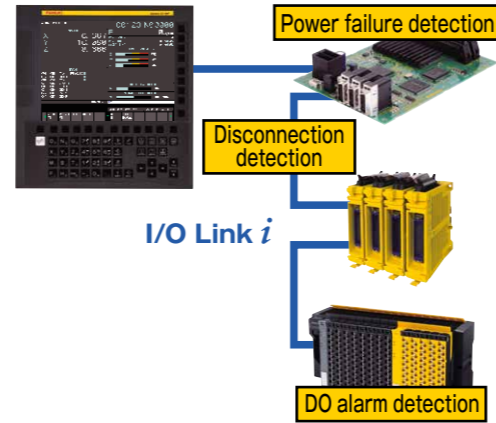
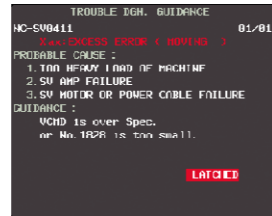

Encoder Communication Check Circuit

This check circuit enables a quick recovery from encoder communication alarm by identifying which part such as encoder, feedback cable or servo amplifier has failed.



Reduction of Recovery Time

FANUC Slice I/O

Exchangeable of electronics housing without removing wires due to 3-Pieces Structure; "Front connector", "Electronics" and "Base".

In addition to that, following functions can easily detect failure module.

- LED indication for each signal state and unit status
- Enable voltage check of each I/O terminal
- Display nickname of each module on the front of module

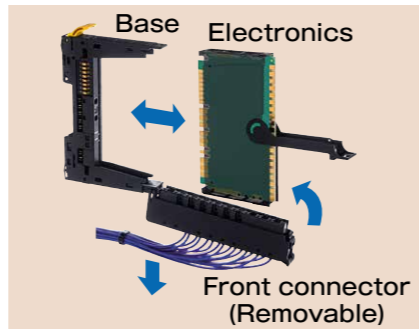

Prevent Machine Damage at Power Failure

Machine Protection at Power Failure

Damage of machines and workpieces at power failure is prevented where a power supply is unstable or in a lightning-prone areas.

- **Gravity-axis drop prevention**
The holding brake of gravity axis are quickly activated by detecting power failure in the circuit incorporated into the amplifier.
- **Stop distance reduction*1)**
Feed axes are quickly stopped to avoid a crash in high-speed machine tools.
- **Retraction*2)**
The tool is retracted from the workpiece while keeping synchronization in gear cutting machines and others.

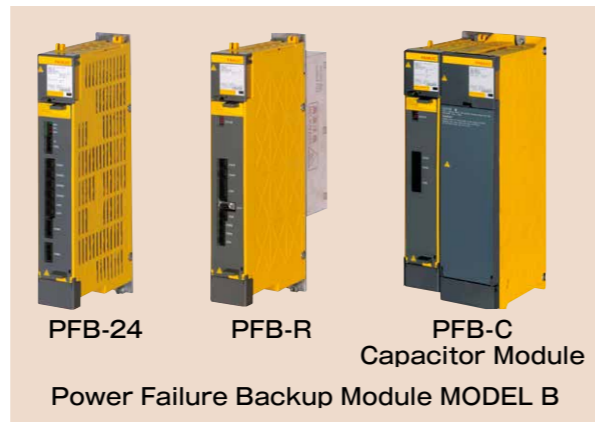

Digital Twin for FANUC CNC

Supporting productivity improvement for machine tool builders and machine users

Supports efficiency for machine tool design, processing and maintenance

FANUC Smart Digital Twin®

Consolidated FANUC CNC technology and Digital technology improves productivity. Part of operation that was available only on machine in the past can be done on PC.

- Improvement of machine utilization rate by not occupying the machine
- Shorten working time by high-speed simulation
- Contribution to energy saving by reducing workpieces and tools for test cutting

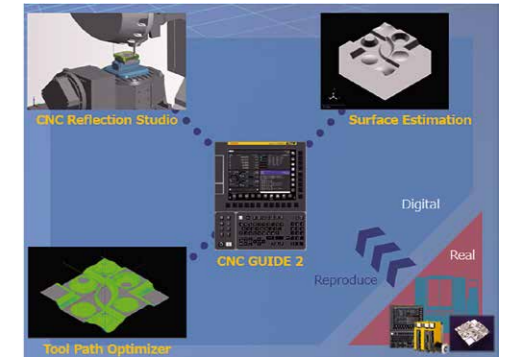

FANUC CNC GUIDE 2

This is a core technology of digital twin for FANUC CNC and a software tool that enables verification of CNC functions on PC.

- Realization of more realistic simulation by using Servo Model which reflects characteristics of controlled axes and the maximum 20 times faster simulation than actual machining
- Simulation of the machine motion and the machined surface working with CNC Reflection Studio and Surface Estimation
- By connecting MOP simulator that integrates MDI and the operation panel, it is possible to train CNC operation with the same operation feeling as an actual machine tool

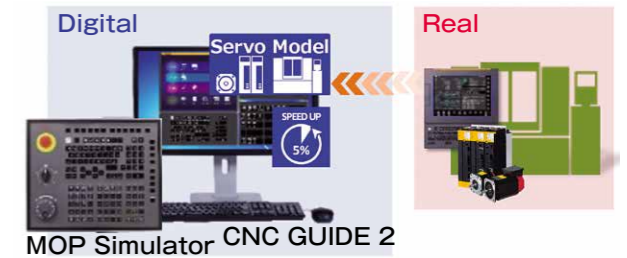

FANUC CNC Reflection Studio

It is a software tool that visualizes machine movement according to machining program execution.

- Safe and high-speed machine collision check can be done in digital space
- G-code analysis/interpolation processing are equivalent to actual CNC by cooperation with CNC GUIDE 2

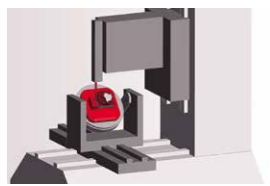

Collision check of machine

FANUC SERVO VIEWER Surface Estimation

It is a software tool that estimates machining surface accurately using position data of CNC GUIDE 2 machining program execution or dry running of actual machine.

- Surface quality issue like streaks can be checked digitally before actual cutting
- Trouble shooting becomes easier by understanding relation between surface and machining program or used tools

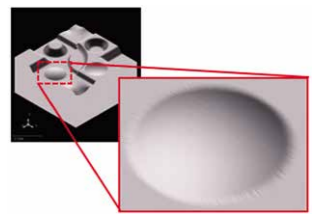

Surface quality evaluation

FANUC Tool Path Optimizer

It is a software tool that compensates the tool path using the machining shape (CAD data).

- Machining program is optimized for FANUC CNC regardless of type of CAM software that generated the machining program
- The quality of the machined surface is improved by reducing scratches and steps on the machined surface caused by the tool path

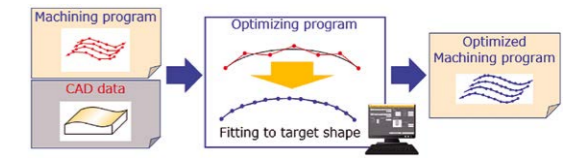

Machining program optimization

Support of Efficient Servo Tuning for High-Speed and High-Precision Machining

FANUC SERVO GUIDE Plus

Integrated tuning tool for Servo and Spindle

SERVO GUIDE Plus helps to improve machining performance through the various waveform analysis and the optimization of servo/spindle parameters according to machine characteristics.

- All in one package for servo tuning including data measurement, parameter management and test program preparation
- Various views of waveform helps easy analysis of machine condition
- AI Servo Tuning is an auto-tuning algorithm with artificial intelligence. It can optimize parameters easily and in a short time.
- 3-D View Function (option) visualizes the tool path and path error and helps trouble shooting of 5-axis machining

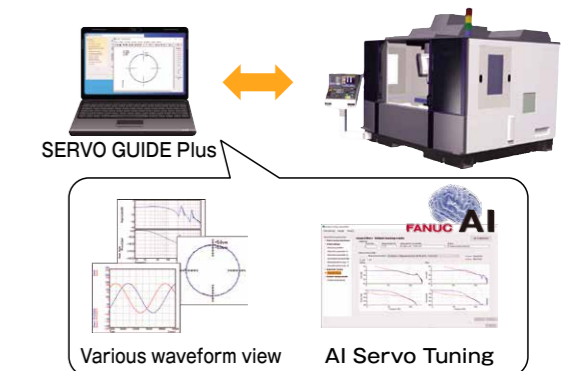

Service & Support

Excellent Maintenance Services

FANUC service team delivers customer trust and confidence based on direction of service “Maximizing Uptime”, “Global Service” and “Lifetime maintenance”.

Service First

Conforming to the spirit of “Service First”, FANUC provides lifetime maintenance to its products for as long as they are used by customers, through more than 270 service locations supporting more than 100 countries and regions throughout the world.

Maximizing Uptime



Global
Service



Lifetime
Maintenance

FANUC ACADEMY

FANUC ACADEMY operates versatile training courses to develop skilled engineers effectively in several days.



Academy

FANUC CORPORATION

● Overseas Affiliated Companies

FANUC America Corporation

FANUC Europe Corporation, S.A.

BEIJING-FANUC Mechatronics CO., LTD

KOREA FANUC CORPORATION

TAIWAN FANUC CORPORATION

FANUC INDIA PRIVATE LIMITED

Phone: (+1)248-377-7000

Phone: (+352)727777-1

Phone: (+86)10-6298-4726

Phone: (+82)55-278-1200

Phone: (+886)4-2359-0522

Phone: (+91)80-2852-0057

<https://www.fanucamerica.com/>

<https://www.fanuc.eu/>

<https://www.bj-fanuc.com.cn/>

<https://www.fkc.co.kr/>

<https://www.fanuctaiwan.com.tw/>

<https://www.fanucindia.com/>

● Headquarters 3580, Shibokusa, Oshino-mura,
Minamitsuru-gun Yamanashi, 401-0597, JAPAN
Phone: (+81)555-84-5555 <https://www.fanuc.co.jp/>

• All specifications are subject to change without notice.
• No part of this catalog may be reproduced in any form.
• The products in the FANUC Series 0i-MODEL F Plus listed in this catalog are not subject to Items 2 to 15 in the Attachment to the Foreign Exchange Order of the “Foreign Exchange and Foreign Trade Law” but are subject to Item 16 (catch-all controls).
The export from Japan may be subject to an export license by the government of Japan.
Further, re-export to another country may be subject to the license of the government of the country from where the product is re-exported. Furthermore, the product may also be controlled by re-export regulations of the United States government.
Should you wish to export or re-export these products, please contact FANUC for advice.

© FANUC CORPORATION, 2019
FS0i-F Plus(E)-05, 2026.3, Printed in Japan