

FANUC ROBODRILL DDRiB



Max. rotation speed
300 min⁻¹(*1)

Indexing 180°
0.27 s (*1)

Clamp torque
700 N·m

Indexing accuracy
±0.0028°

FEATURES

- Non-backlash, high-speed and high-precision machining by direct drive motor and *aiCZ* sensor
- Rigidity enhancement by optimizing the shape of casting body
- Achieving quicker action and higher clamp torque by new clamp mechanism
- Initial setting and automatic parameter adjustment according to mounted fixture by **DDR** setting screen

Application example

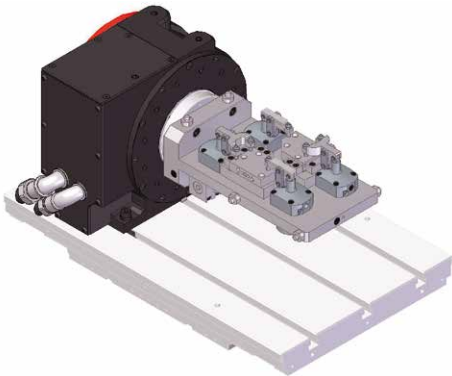

Comparison with the previous model

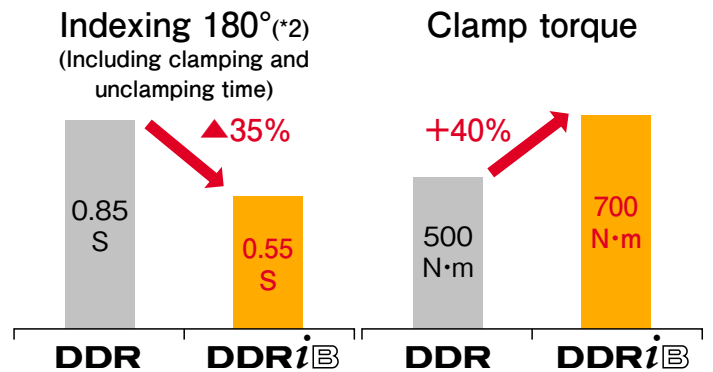

DDR setting screen

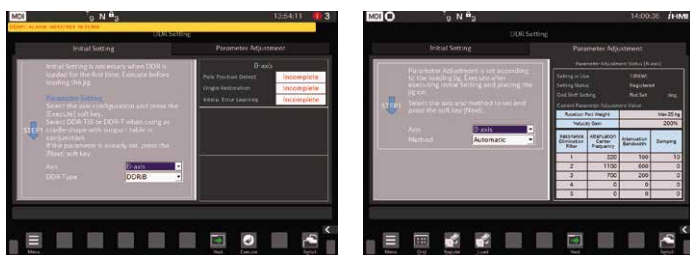

Initial setting

Parameter adjustment

Options

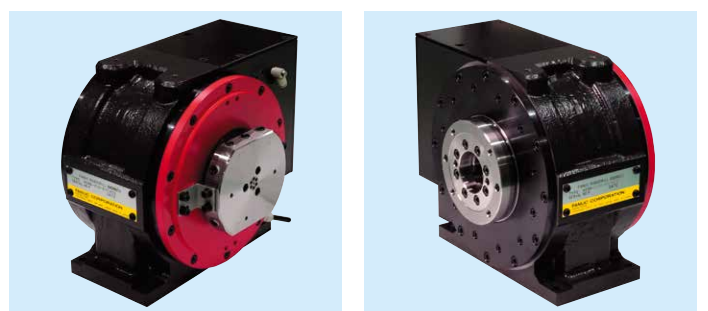

Rotary joint

End plate

*1 : When loading mass is under 25 kg and workpiece inertia is under 0.25 kg·m².
 When rotation speed is 300 min⁻¹, continuous rotation cannot be performed. (Use only for indexing.)
 *2 : When loading mass is under 50 kg and workpiece inertia is under 0.5 kg·m².

Outer dimensions

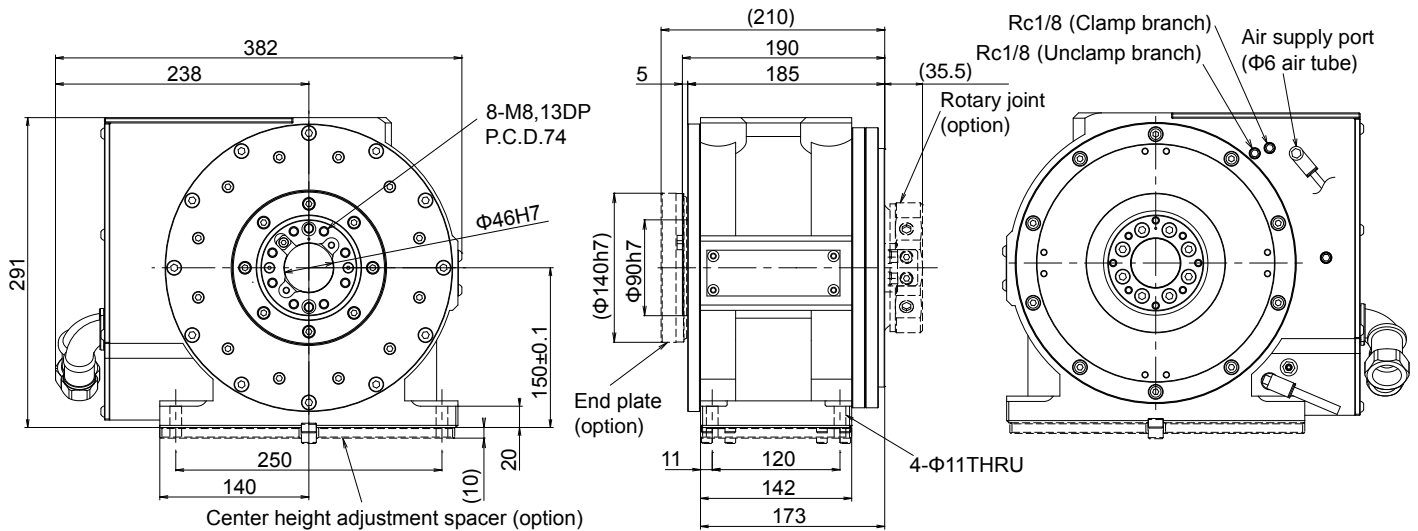

Specifications

No.	Items	Specifications	Remarks
1	Drive system	Direct drive	
2	Cooling system	None	
3	Maximum torque	275 N·m	
4	Continuous rating	46 N·m	
5	Maximum rotation speed	300 min ⁻¹	200 min ⁻¹
6	Maximum loading mass	25 kg	100 kg
7	Allowable workpiece inertia	J = 0.25 kg·m ² (GD ² = 1.0 kgf·m ²)	J = 1.0 kg·m ² (GD ² = 4.0kgf·m ²)
8	Feedrate	1°/min to 30000 °/min	
9	Least input increment	0.0001°	
10	Index accuracy	±0.0028° (±10")	
11	Clamp system	Air pressure + spring	
12	Clamp torque	700 N·m with 0.5 MPa air supply 100 N·m without air supply	500 N·m with 0.35 MPa air supply
13	Table inertia	J = 0.04 kg·m ² (GD ² = 0.16 kgf·m ²)	
14	Allowable moment load	F ₁ ·L = 600 N·m	
15	Allowable thrust load	F ₂ = 4000 N	
16	Spindle outside diameter	φ90 mm	φ 140 mm with an endplate (option)
17	Spindle hole diameter	φ46 mm through	φ 55 mm with an endplate (option)
18	Center height	150 mm ±0.1 mm	160 mm ±0.01 mm with a center height adjustment (option)
19	Mass	80 kg	+2kg with an endplate (option) +6kg with a rotary joint (option)
20	Rotary joint (option)	Number of ports : 6 Maximum pressure : air 0.5 MPa hydraulic 5 MPa (standard) / 20 MPa (high pressure)	

FANUC CORPORATION

3580, Shibokusa, Oshino-mura, Minamitsuru-gun, Yamanashi, 401-0597, JAPAN
Phone: (+81)555-84-5555 <https://www.fanuc.co.jp/>

•All specifications are subject to change without notice.
•No part of this catalog may be reproduced in any form.
•The photo includes options.
•The products in this catalog are controlled based on Japan's "Foreign Exchange and Foreign Trade Law". The export of these products from Japan is subject to an export License by the government of Japan.
Further, re-export to another country may be subject to the license of the government of the country from where the product is re-exported.
Furthermore, the product may also be controlled by re-export regulations of the United States government.
•Should you wish to export or re-export these products, please contact FANUC for advice.