

## INSTALLATION CONDITION FOR UL RECOGNITION

⑤

For UL recognition of the product, FANUC Series 0i-MODEL F and FANUC Series 0i-MODEL F Plus shall be installed after due considerations on UL requirements.

1. Environmental conditions
  - Indoor use
  - Altitude up to 1,000 m (Operating)
  - Operating ambient temperature (The temperature inside the equipment):
    - 0°C to 58°C for LCD-mounted type
    - 0°C to 55°C for Stand-alone type
  - Humidity (Operating): 75%RH or less, no condensation
  - Use the equipment in Pollution degree 2 \*1 environment or cleaner environment (\*1. "Pollution Degree 2" is defined in the standard UL/CSA. )
2. Technical specifications

No	Model	Input		Enclosure *2)	Remarks
		Volt	[A]		
1	A02B-0338-B502	DC24V	3.2A	Type 1	LCD-mounted type Basic unit A
2	A02B-0338-B501	DC24V	3.0A	Type 1	LCD-mounted type Basic unit A
3	A02B-0338-B500	DC24V	2.4A	Type 1	LCD-mounted type Basic unit A
4	A02B-0338-B520	DC24V	2.4A	Type 1	LCD-mounted type Basic unit C
5	A02B-0338-B512	DC24V	3.5A	Type 1	LCD mounted type Basic unit G
6	A02B-0338-B510	DC24V	2.7A	Type 1	LCD-mounted type Basic unit G
7	A02B-0338-B802	DC24V	3.9A	Open Type	Stand-alone type Basic unit B
8	A02B-0348-B502	DC24V	3.2A	Type 1	LCD-mounted type Basic unit A
9	A02B-0348-B501	DC24V	3.0A	Type 1	LCD-mounted type Basic unit A
10	A02B-0348-B500	DC24V	2.4A	Type 1	LCD-mounted type Basic unit A
11	A02B-0348-B512	DC24V	3.5A	Type 1	LCD mounted type Basic unit G
12	A02B-0348-B511	DC24V	3.3A	Type 1	LCD mounted type Basic unit G
13	A02B-0348-B510	DC24V	2.7A	Type 1	LCD-mounted type Basic unit G
14	A02B-0348-B802	DC24V	3.9A	Open Type	Stand-alone type Basic unit B

(\*2. Open type, Type 1 - Open type and Type 1 are defined in the standard UL/CSA.

3. Power supply unit for the equipment must have a double insulation or reinforced insulation device and the output voltage must be less than DC 60 V. However, input voltage to the control unit shall not exceed DC 26.4 V.  
(The insulation can be achieved with the use of an insulated DC power supply unit that complies with UL/CSA standard.)
4. Use the input power cable and the connector as following.  
Housing: Tyco Electronics 1-178288-3  
Contact: Tyco Electronics 1-175218-5  
Wire: Copper conductors 20AWG or thicker
5. If the equipment is used in a manner not specified by the manufacturer, the protection provided by the equipment may be impaired.
6. Equipment installation
  - 6.1 The control unit and the peripheral units have been designed on the assumption that they are housed in closed cabinets. The cabinet should basically be made of metal.
  - 6.2 Set up the LCD-mounted type control unit, the display unit, and the MDI unit on a flat surface of a Type 1 Enclosure.

### 6.3 Installing the LCD-mounted type control unit

Air is fed into the control unit from the bottom, drawn by the fan motors which are located on the top of the control unit.

Space (A), shown in the figure below, must be provided to ensure unrestricted air flow. Also, space (B) should be provided whenever possible. When space (B) cannot be provided, ensure that nothing is placed in the immediate vicinity which could obstruct the air flow.

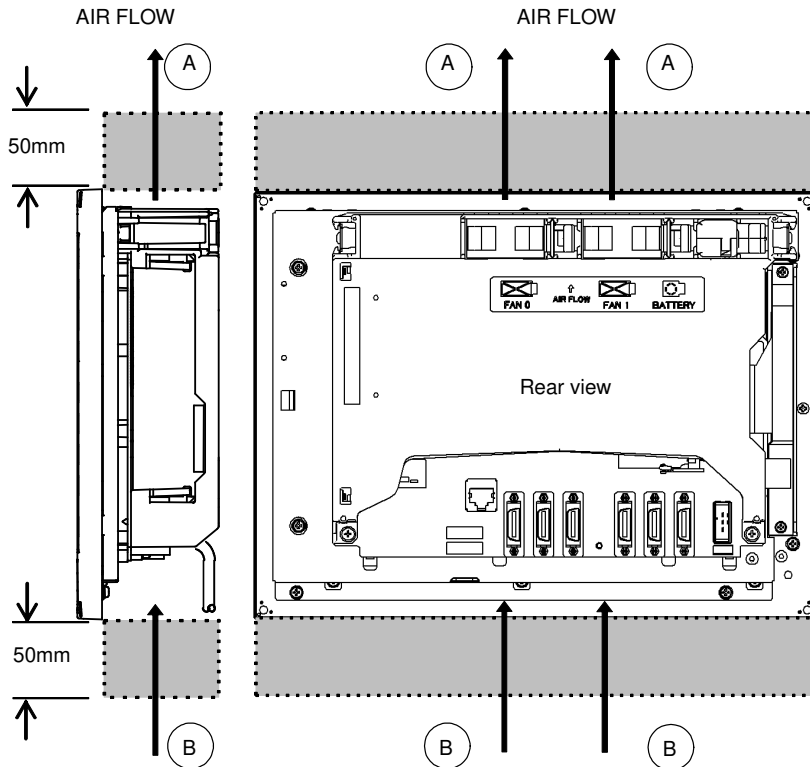

### 6.4 Installing the Stand-alone type control unit

Air is fed into the control unit from the bottom, drawn by the fan motors which are located on the top of the control unit. The spaces shown in the figure below (areas (A) and (B)) must be provided to ensure smooth air flow.

Also, adequate service access space is required in front of and at the top of the unit so that printed circuit boards and the fan motor can be replaced easily if necessary.

There is a spare connector located at the far end (at middle height) on the right side of the control unit. This connector is used for control unit testing and other purposes. Therefore, space (area (C)) for handling the connector is required.

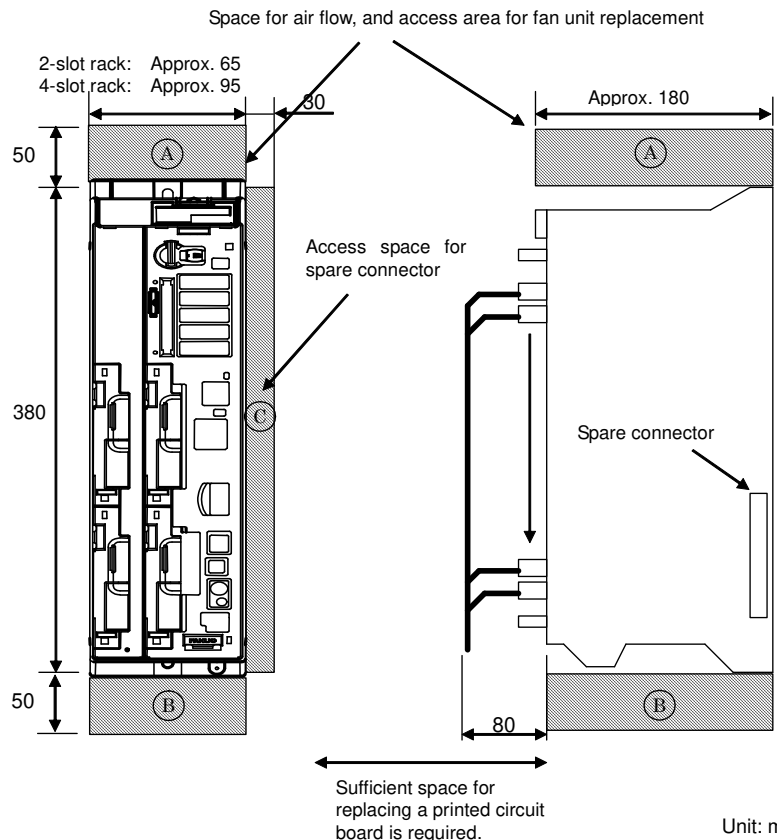

## 6.5 Connecting the Ground Terminal of the Control Unit

Connection between the control unit's ground terminal (which is marked with protective conductor terminal  ) and 0 V. ②

### CAUTION

In the control unit, the 0 V and the ground terminals are electrically connected to each other. So, do not connect any external unit's 0 V connected to the control unit's 0 V to any other line's grounding electrode that can have an electrical potential different from that of the grounding electrode connected to the control unit.

The following table lists the tightening torque for screws and nuts used to fasten the units (except those having molded mounting parts) explained herein and ground terminals in the units.

Screw and nut diameter	Tightening torque
M3	0.8 to 1.0 N·m
M4	1.6 to 2.0 N·m

The following table lists the tightening torque for screws and nuts used to fasten those units having resin parts, such as Stand-alone type control units.

Screw and nut diameter	Tightening torque
M4	1.1 to 1.5 N·m
M5	2.4 to 2.8 N·m

### 6.5.1 Connecting the ground terminal of an LCD-mounted type control unit

Connect the 0 V line in the control unit to the cabinet's metal plate or signal system ground bar nearby via the ground terminal (see below).

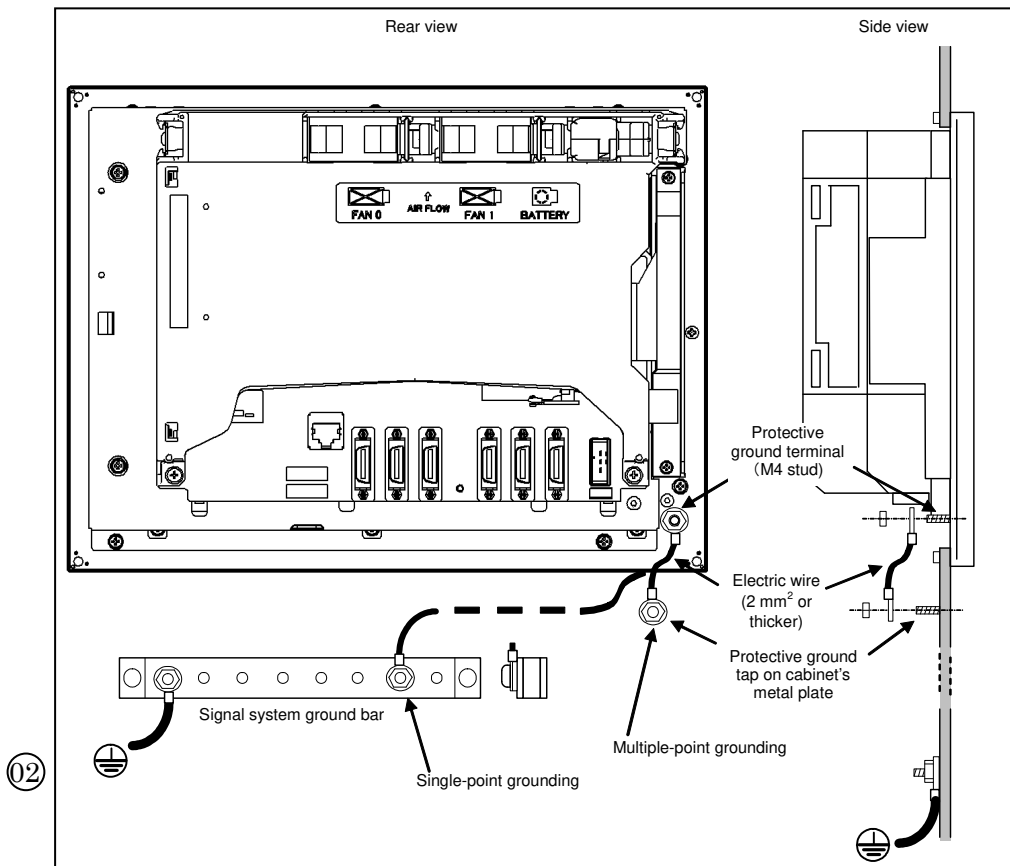

### 6.5.2 Connecting the ground terminal of a Stand-alone type control unit

Connect an electronics circuit's 0 V line in the control unit to the cabinet's metal plate or signal system ground bar close to it via the signal ground terminals.

Use the Fasten terminal, FANUC specification: A02B-0166-K330.

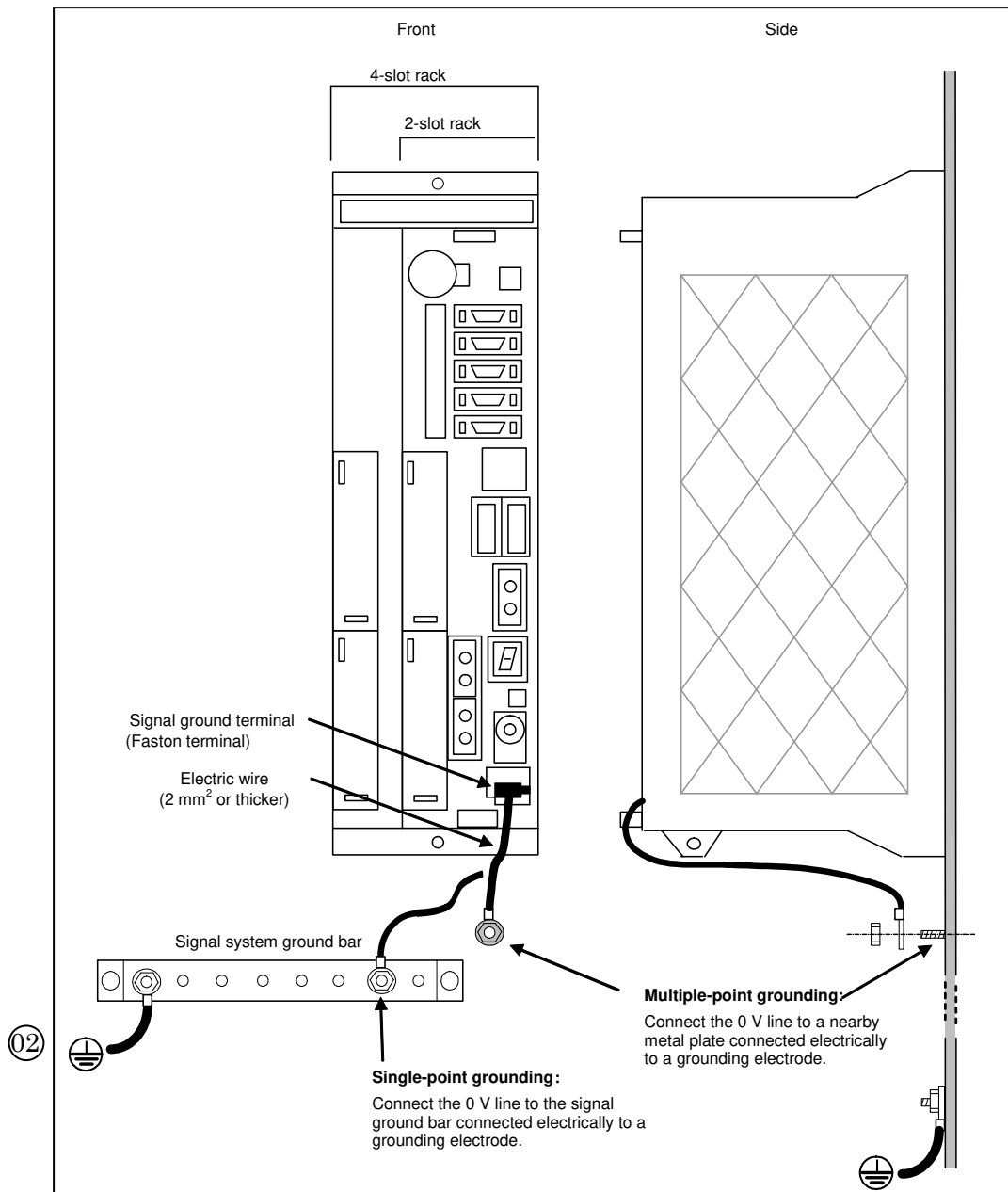

6.6 Outline drawings of units

Name		Panel cutout
LCD-mounted type control unit	8.4" LCD/MDI unit(Horizontal)	Fig. U1
	8.4" LCD/MDI unit(Vertical)	Fig. U2
	8.4" LCD unit	Fig. U3
	10.4" LCD unit	Fig. U4
	10.4" LCD/MDI unit(Horizontal)	Fig. U13
	10.4" LCD/MDI unit B(Horizontal)	Fig. U16
	10.4" LCD/MDI unit(Vertical)	Fig. U14
	10.4" LCD/MDI unit B(Vertical)	Fig. U17
	15" LCD unit	Fig. U5
MDI unit	MDI unit (small type, 200x140mm)	Fig. U6
	MDI unit (ONG, 200x260mm)	Fig. U7
	MDI unit (ONG, 220x230mm)	Fig. U8
	MDI unit (ONG, 220x290mm)	Fig. U9
	MDI unit (ONG or QWERTY TYPE A, 160x290mm)	Fig. U10
	MDI unit (QWERTY TYPE B, 145x400mm)	Fig. U11
	MDI unit (QWERTY TYPE C, 120x500mm)	Fig. U15
Stand-alone type control unit	2 slots	Fig. U12

④  
⑧  
④  
⑧  
④  
⑥

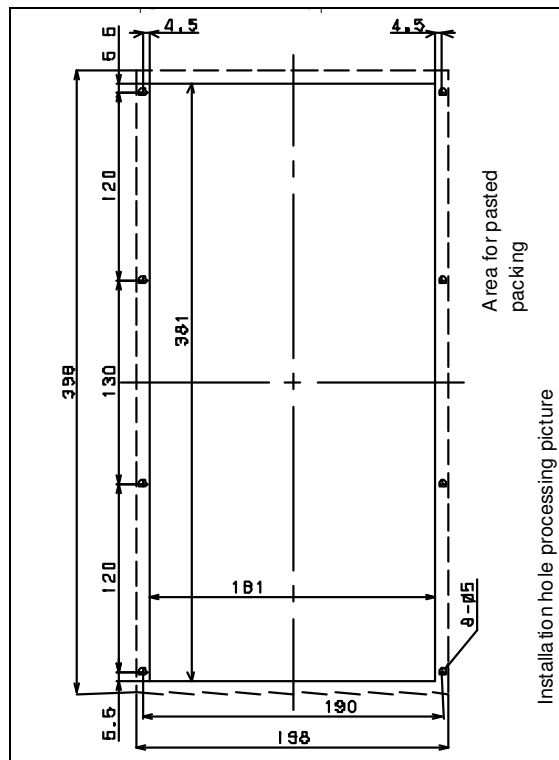

Fig. U1 8.4" LCD/MDI unit(Horizontal)

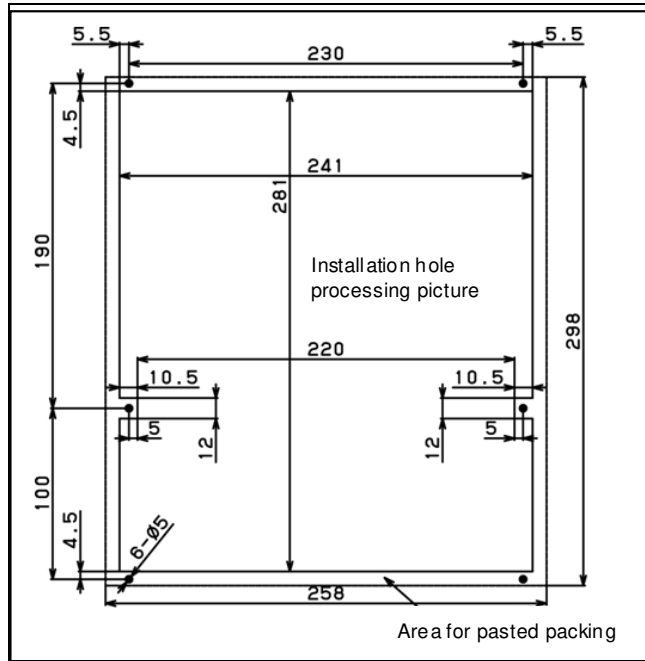

Fig. U2 8.4" LCD/MDI unit(Vertical)

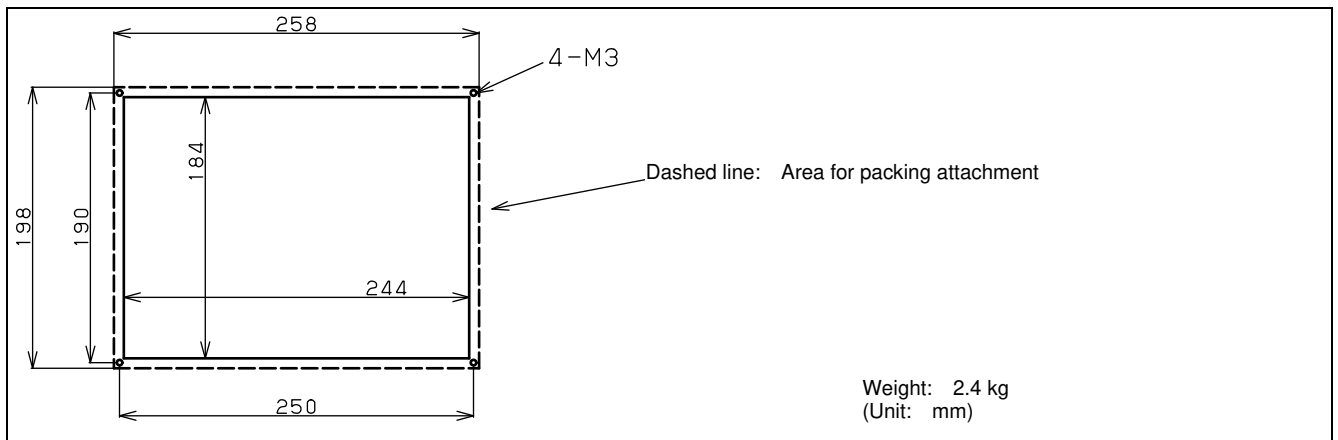

Fig. U3 8.4" LCD unit

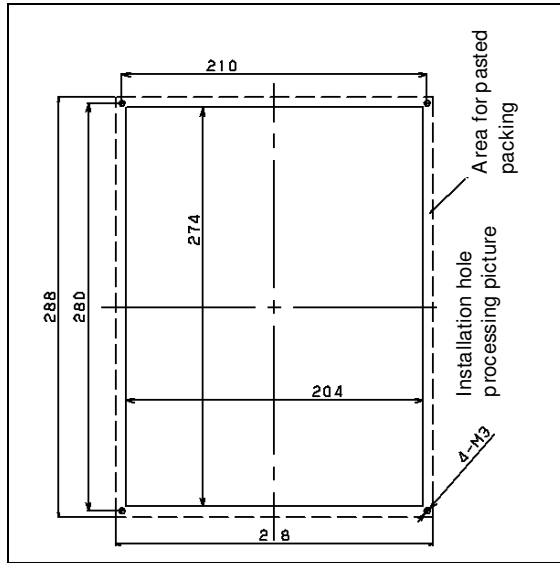

Fig. U4 10.4" LCD unit

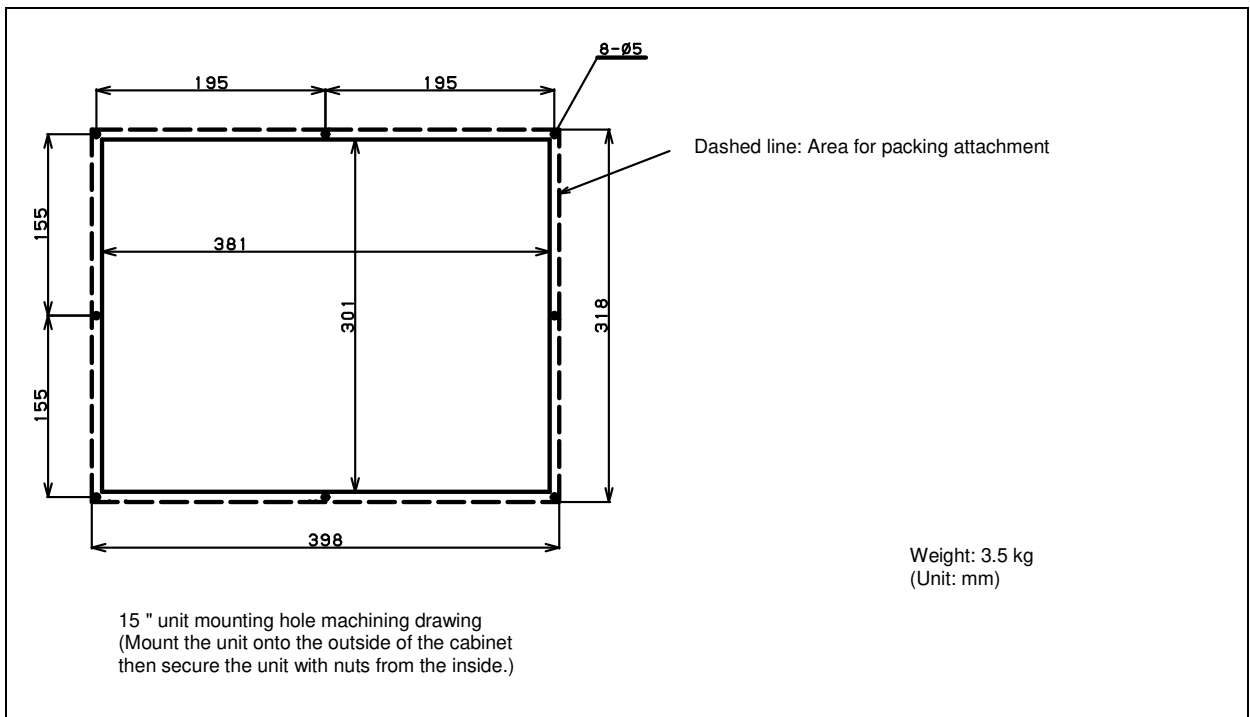

Fig. U5 15" LCD unit

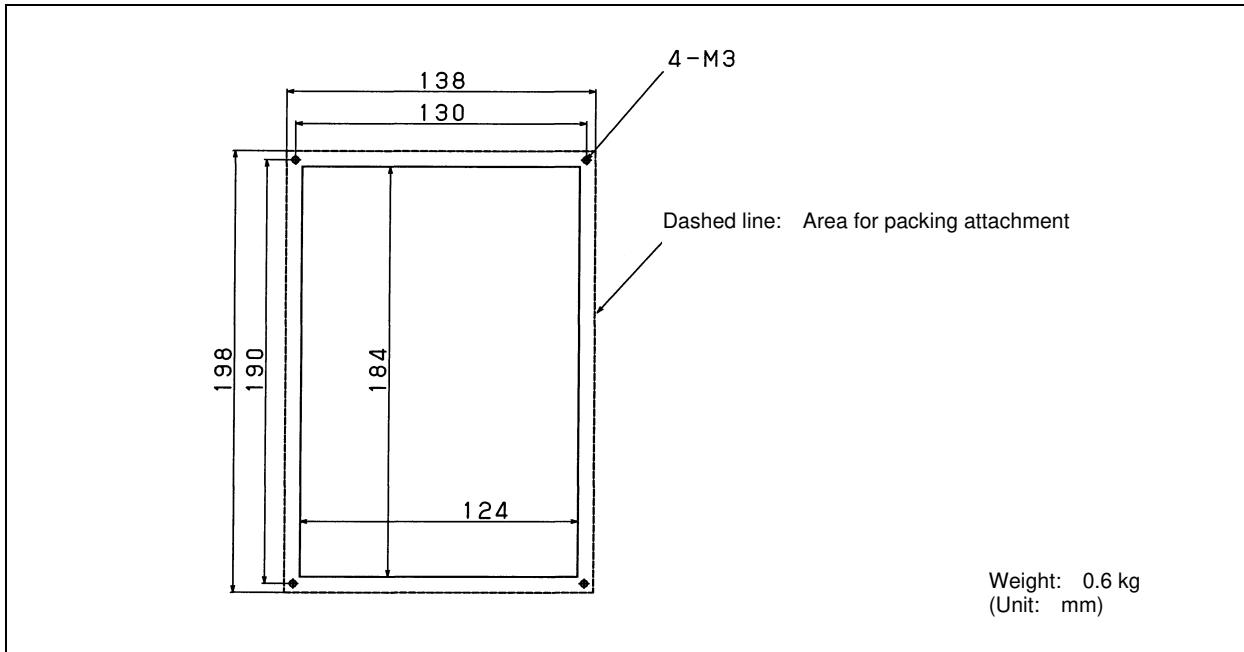

Fig. U6 MDI unit (small type, 200x140mm)

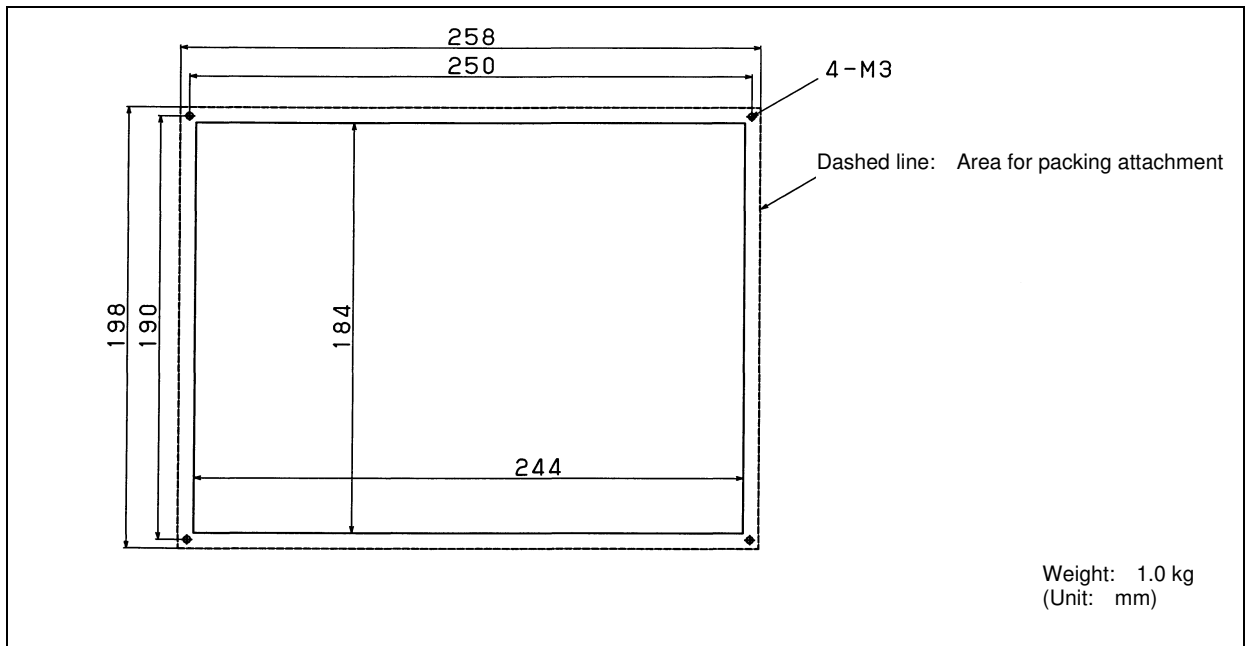

Fig. U7 MDI unit (ONG, 200x260mm)



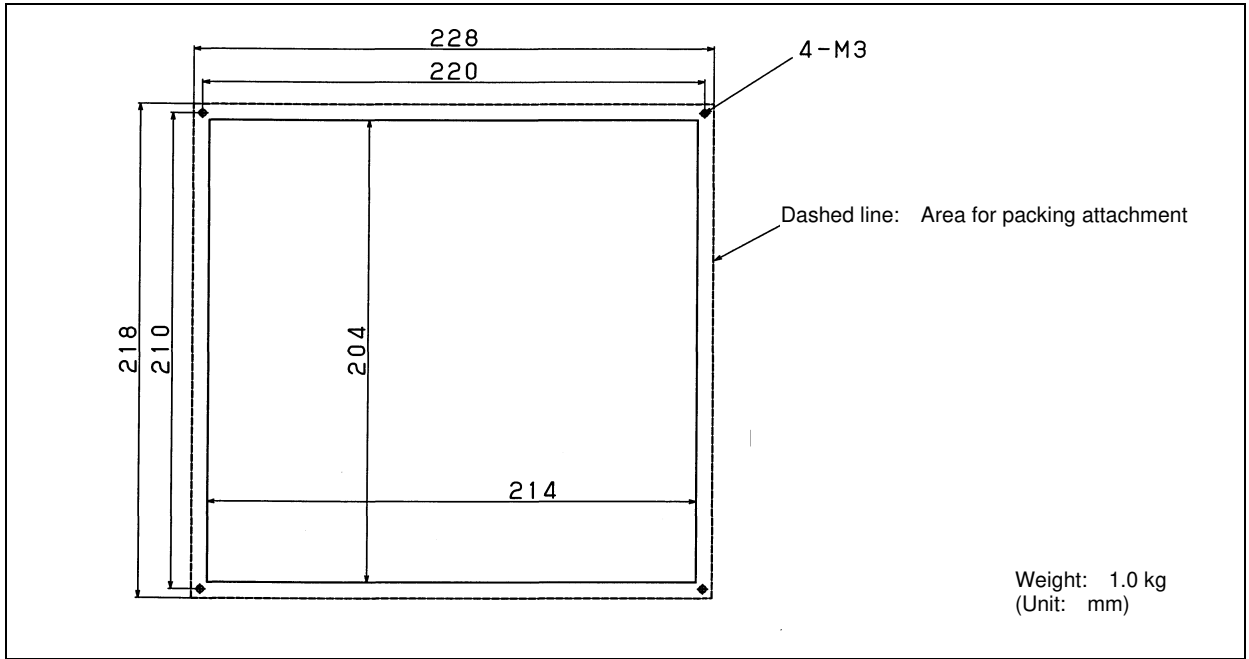

Fig. U8 MDI unit (ONG, 220x230mm)

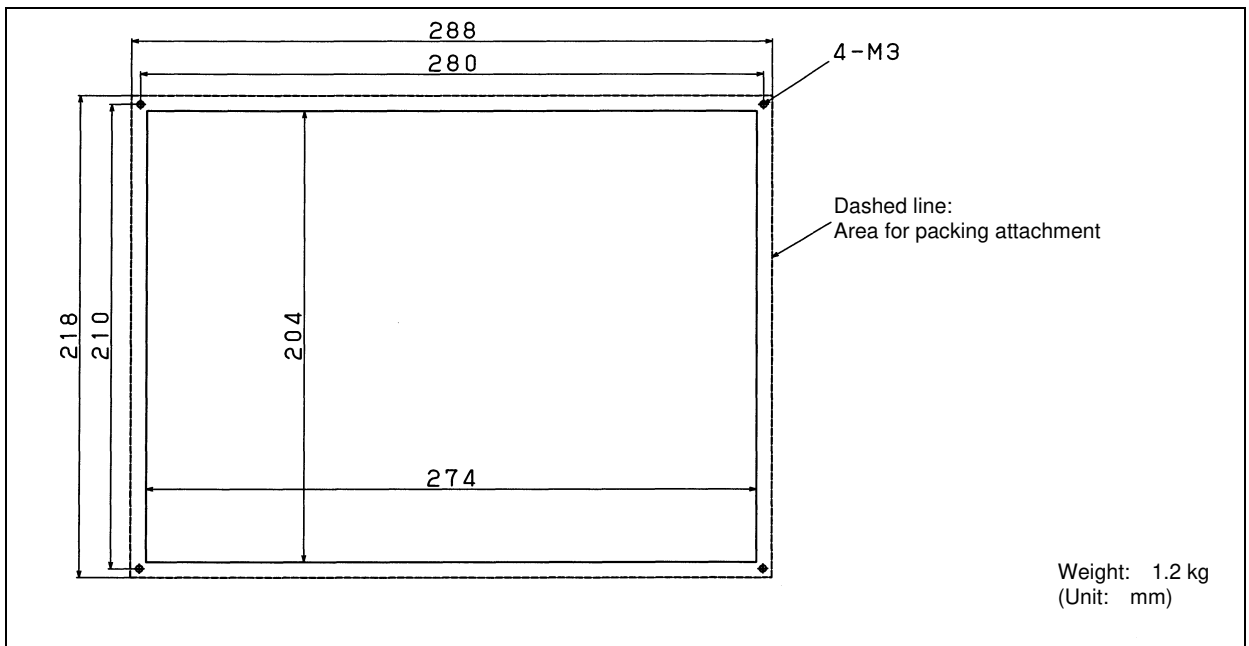

Fig. U9 MDI unit (ONG, 220x290mm)

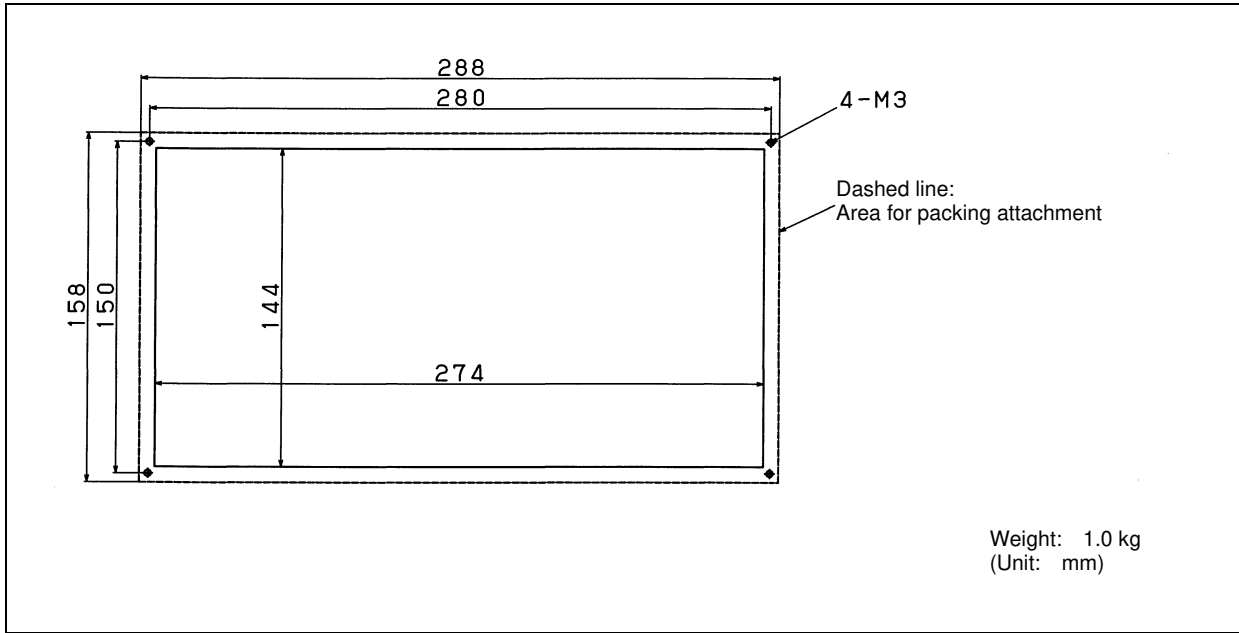

Fig. U10 MDI unit (ONG or QWERTY TYPE A, 160x290mm) ④

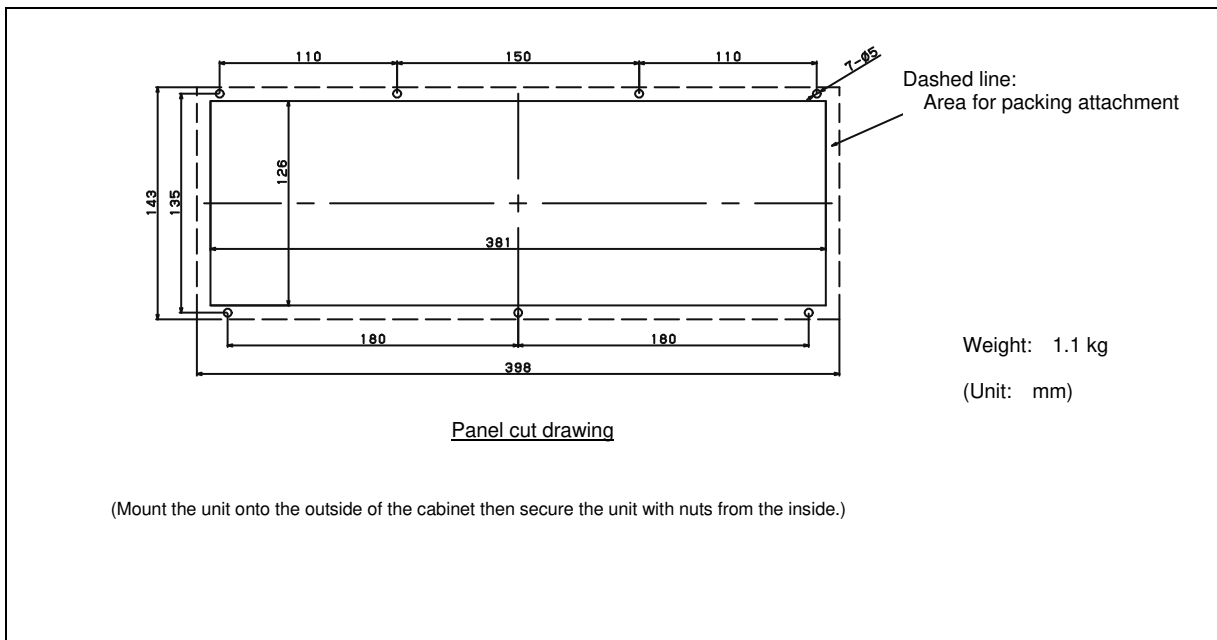

Fig. U11 MDI unit (QWERTY TYPE B, 145x400mm)

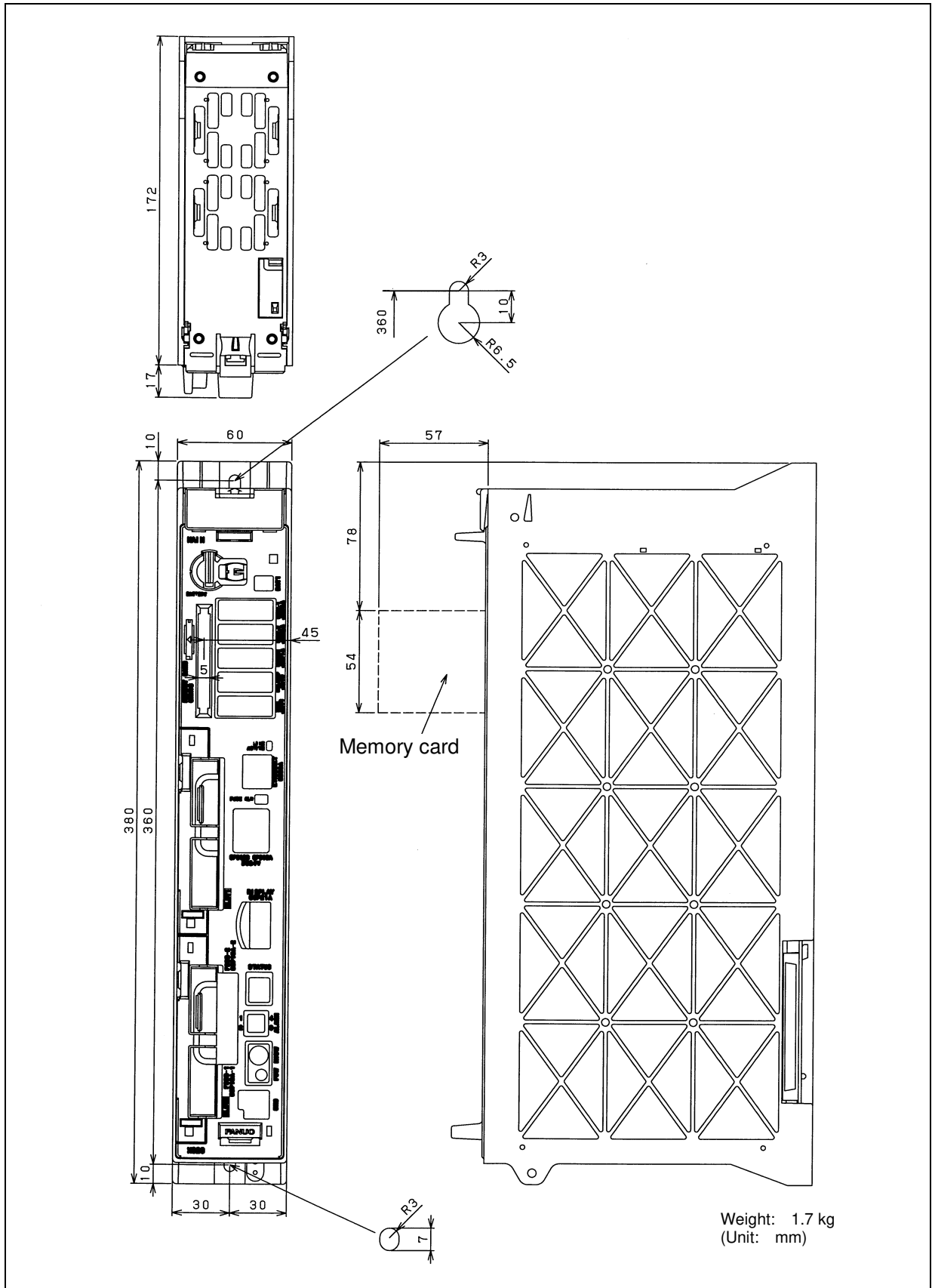

Fig. U12 Stand-alone type control unit

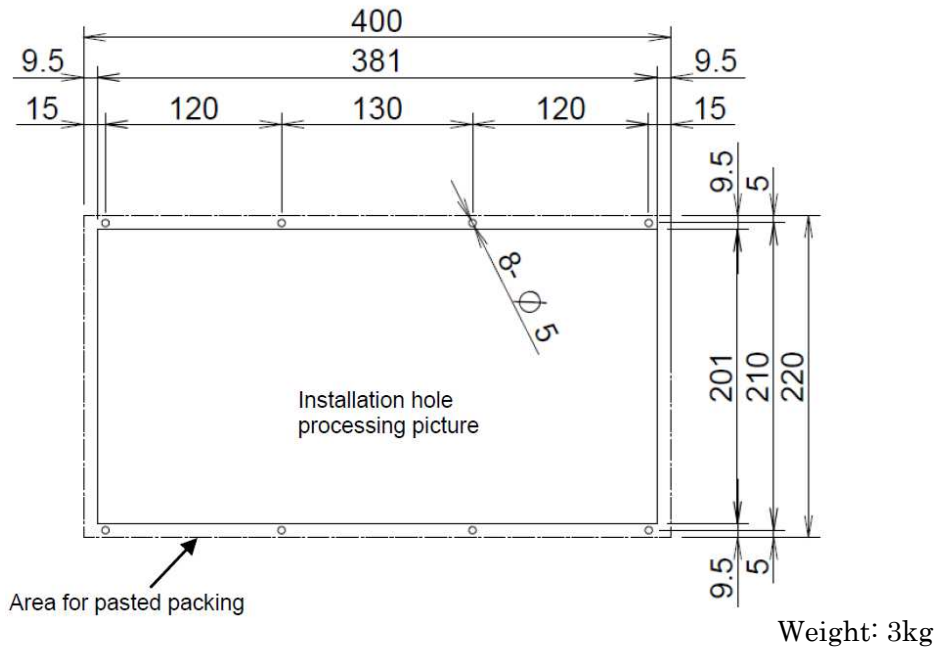

Fig. U13 10.4" LCD/MDI unit(Horizontal) ④

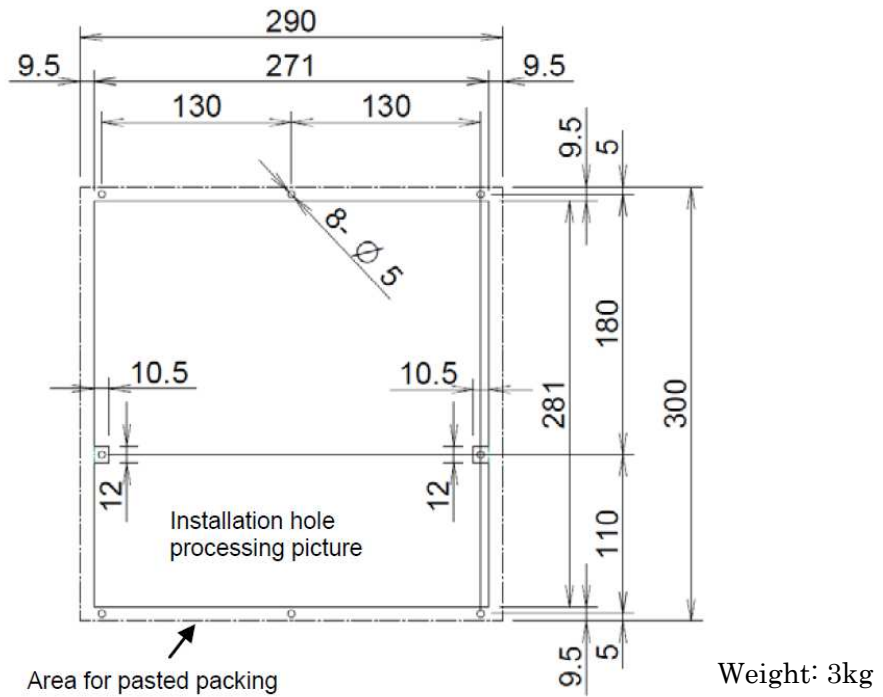

Fig. U14 10.4" LCD/MDI unit(Vertical) ④

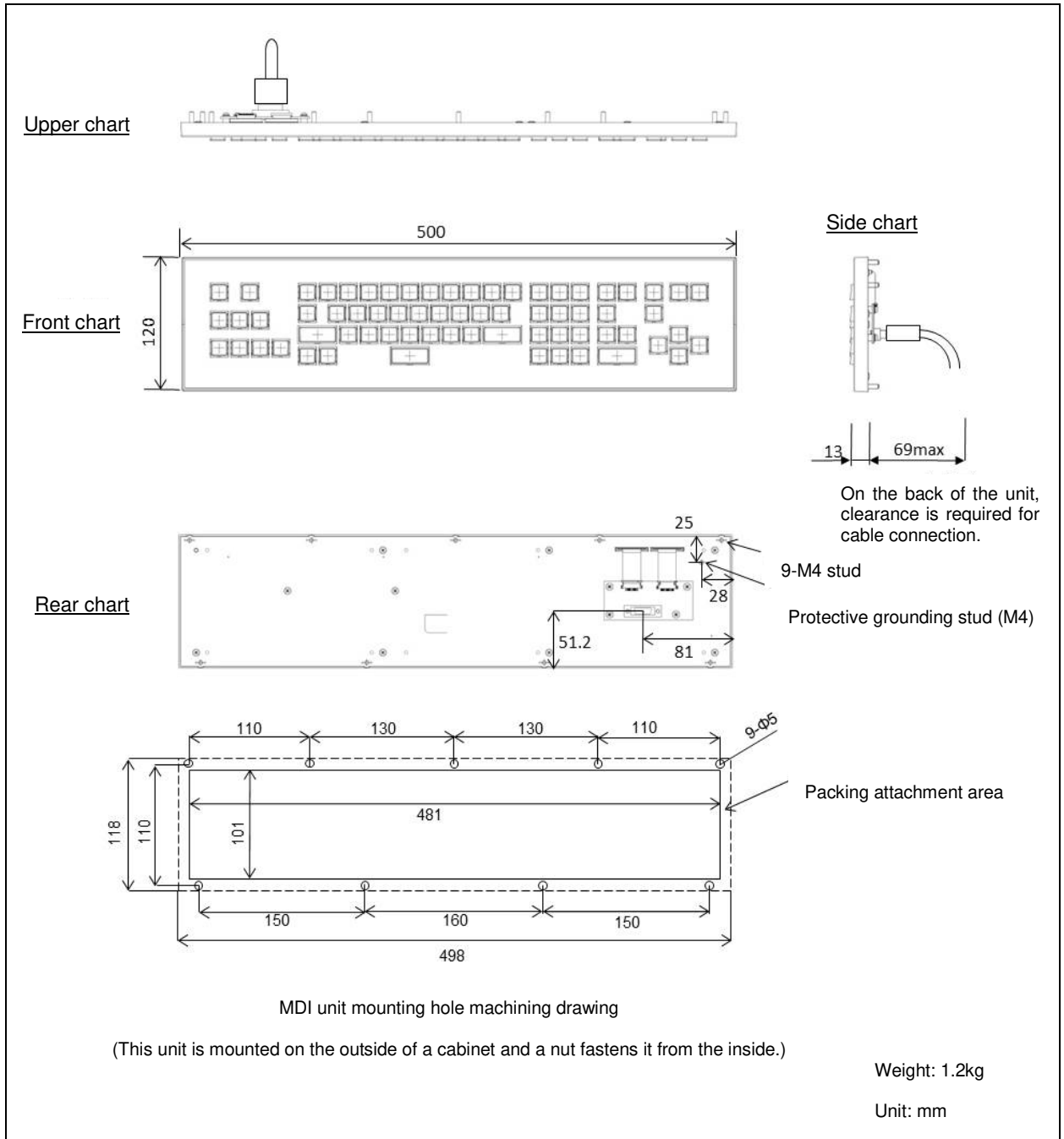

Fig. U15 MDI unit (QWERTY TYPE C, 120x500mm) ①⑥

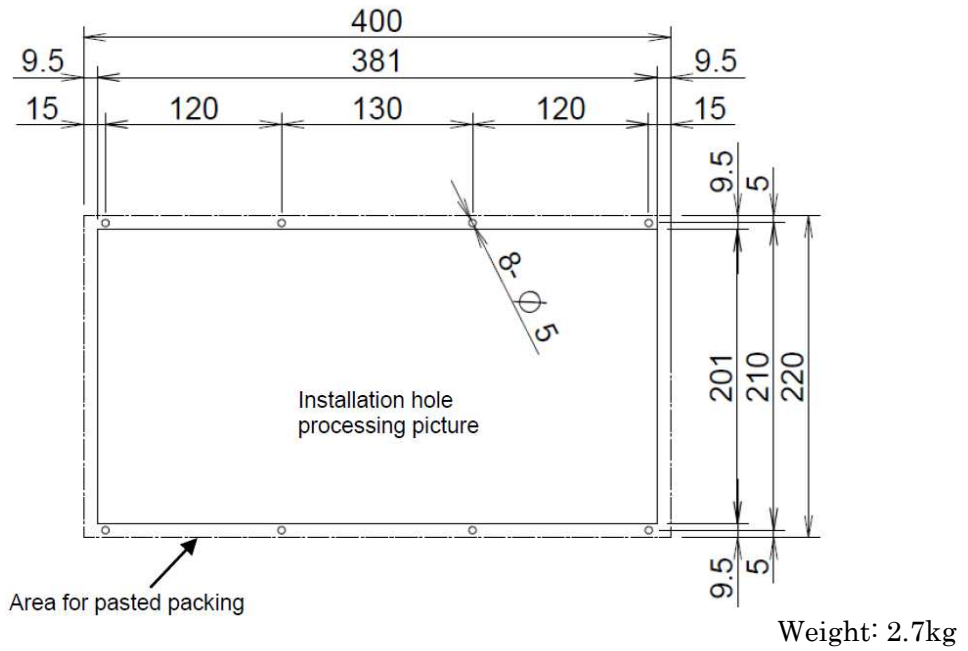

Fig. U16 10.4" LCD/MDI unit B(Horizontal) 08

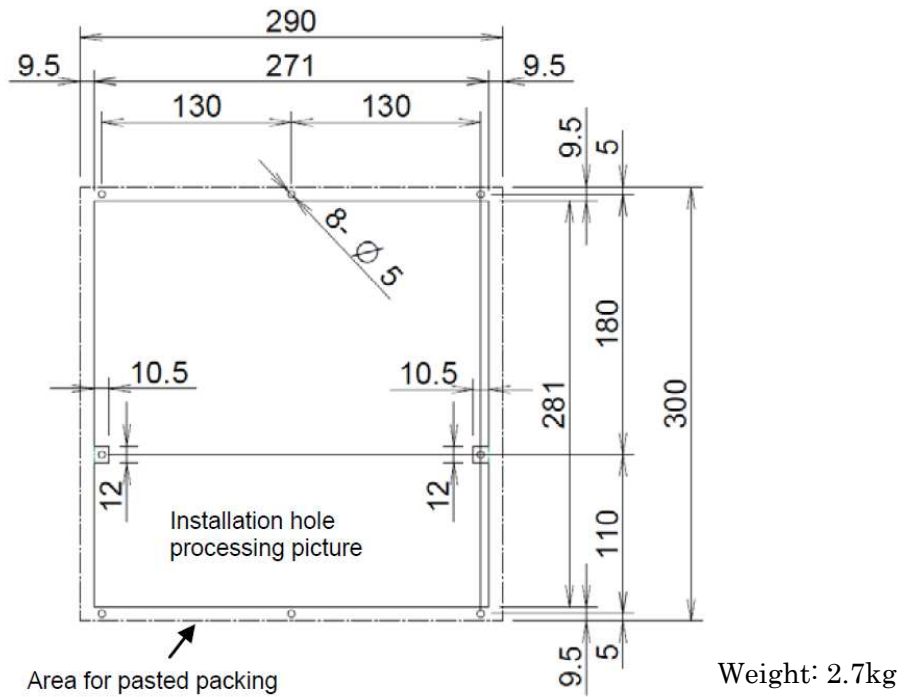

Fig. U17 10.4" LCD/MDI unit B(Vertical) 08

7. Replacing control unit maintenance parts

The maintenance of the control unit involves various danger. It must be undertaken only by a person who is trained in the related maintenance and safety requirements. Before replacing the control unit or its components, be sure to shut off externally supplied power.

7.1 Replacing fuses

**⚠ WARRING**  
 Before replacement of a blown fuse, its cause must be corrected. So, fuse replacement work must be done only by a person who is trained in the related maintenance and safety requirements.

**Fuse-mounting location of the LCD-mounted type control unit**

- Basic unit A and Basic unit C

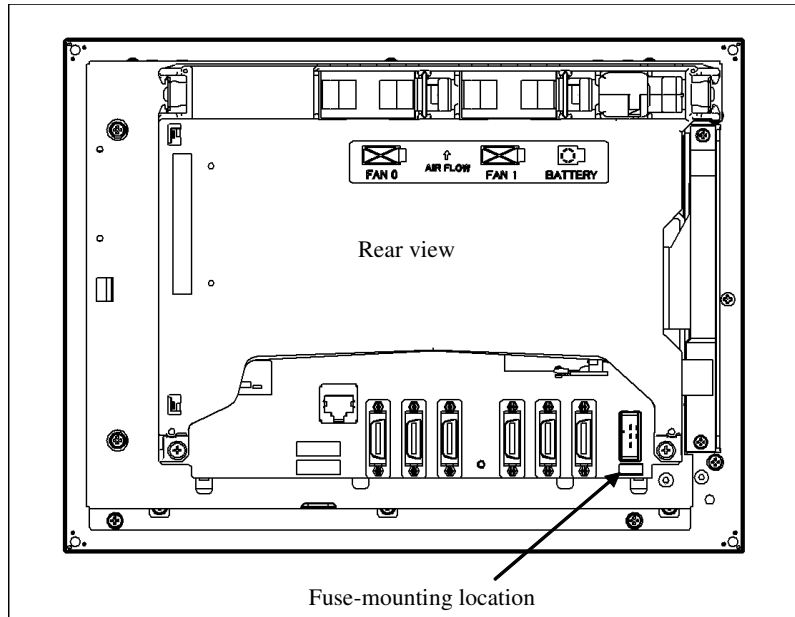

Fuse specification

Specification	Rating
A02B-0236-K100	5A

- Basic unit G

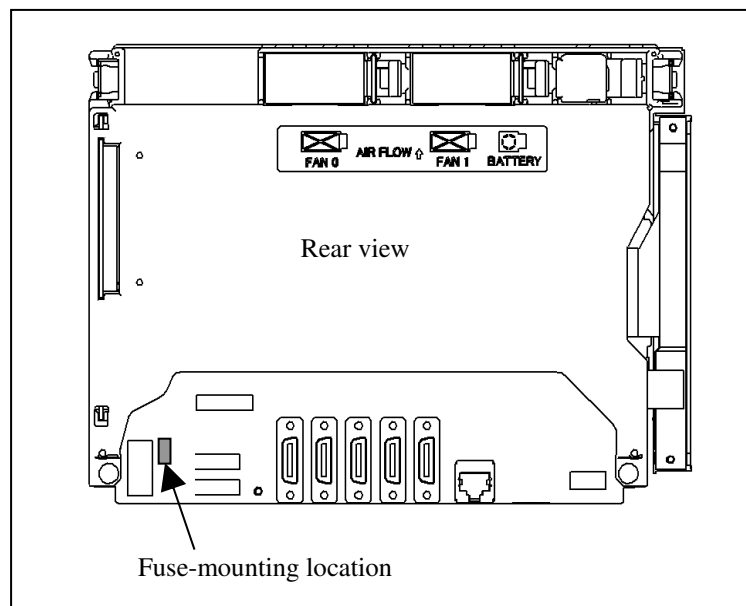

#### Fuse specification

Specification	Rating
A02B-0236-K100	5A

#### Fuse-mounting location of the Stand-alone type control unit

- Basic unit B

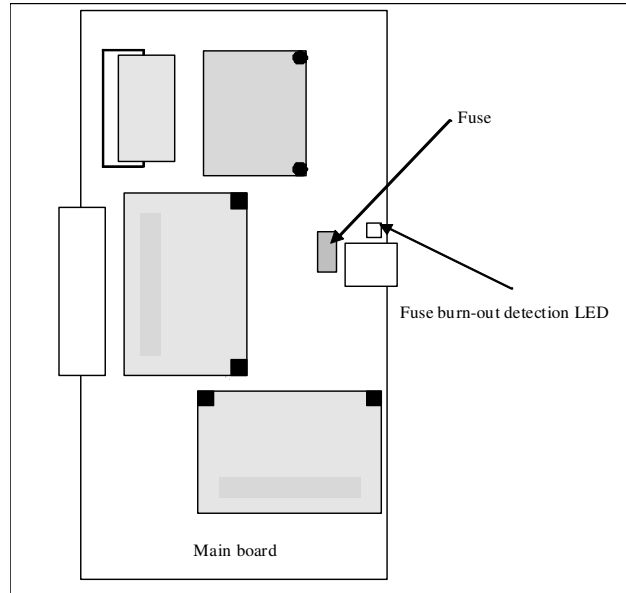

The fuse is on the main board. Before replacing the fuse, pull out the main board from the control unit.

#### Fuse specification

Specification	Rating
A02B-0319-K100	5A

#### 7.2 Replacing the battery for memory backup in the control unit

##### For LCD-mounted type control unit

Prepare a new lithium battery (ordering code: A02B-0323-K102).

- ① Turn the power to the machine (control unit) on. After about 30 seconds, turn the power off.
- ② Pull out the lithium battery on the back of the control unit (Hold the latch of the lithium battery, and pull the lithium battery toward you while releasing the claw from the case).

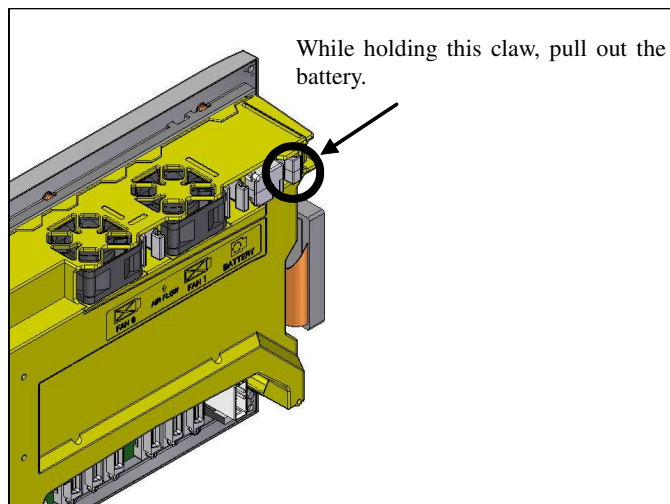



- ③ Put a new lithium battery into the control unit. (Push the battery so that the catch is latched with the case.) Confirm that the catch has been latched securely.

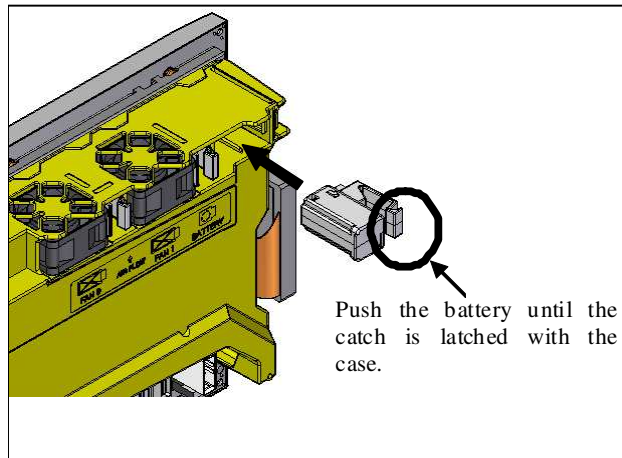

**⚠ WARNING**

Using other than the recommended lithium battery may result in the battery exploding.  
Replace the battery only with the specified lithium battery (A02B-0323-K102).

**For Stand-alone type control unit**

Prepare a new lithium battery (ordering code: A02B-0200-K102).

- ① Turn the power to the machine (control unit) on. After about 30 seconds, turn the power off.
- ② Remove the lithium battery on the upper section of the control unit.  
First, unplug the connector by yanking the battery cable, and then take the battery out of its case.  
The battery case is located in the upper section of the face plate of the main board.
- ③ Insert a new lithium battery and reconnect the connector.

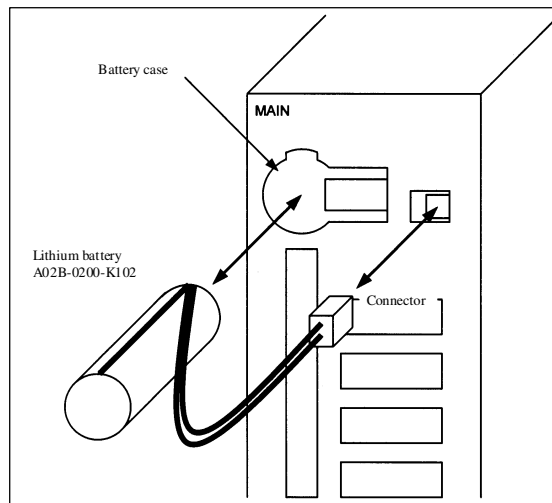

**⚠ WARNING**

Using other than the recommended lithium battery may result in the battery exploding.  
Replace the battery only with the specified lithium battery (A02B-0200-K102).

### 7.3 Replacing a FAN motors

#### For LCD-mounted type control unit

- ① When replacing the fan motor, be sure to turn off the power to the control unit.
- ② Remove the fan motor from the case by holding fan motor's latch and pulling it out while releasing the claw from the case.
- ③ Put the fan motor into the case. After that, make sure that the fan motor's claw has latched the case securely.

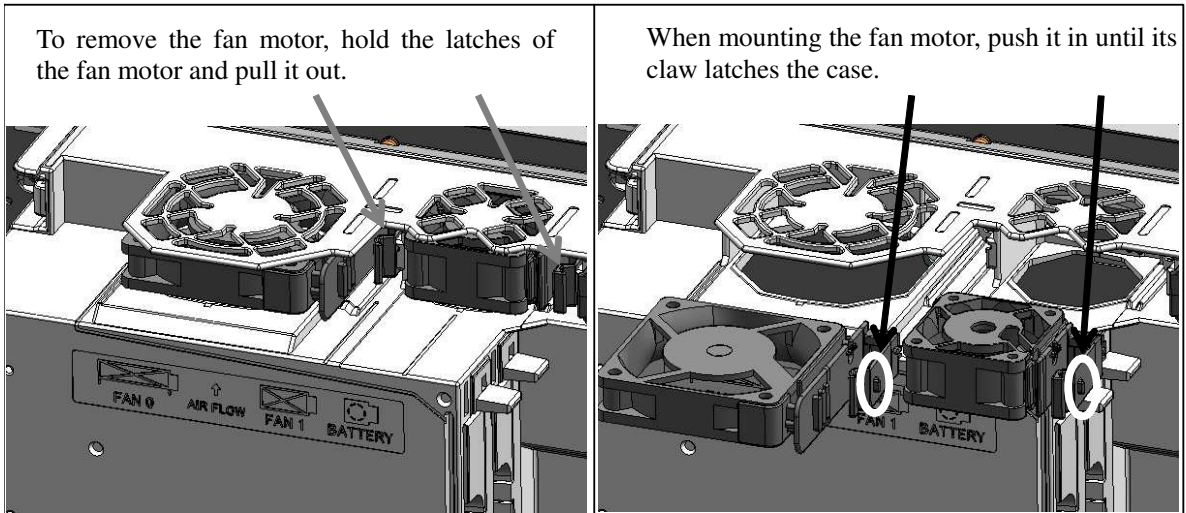

#### For Stand-alone type control unit

##### Detaching fan unit

- ① When replacing the fan unit, be sure to turn off the power to the control unit.
- ② Push up the latch at the top of the fan unit so that the latch is disengaged.

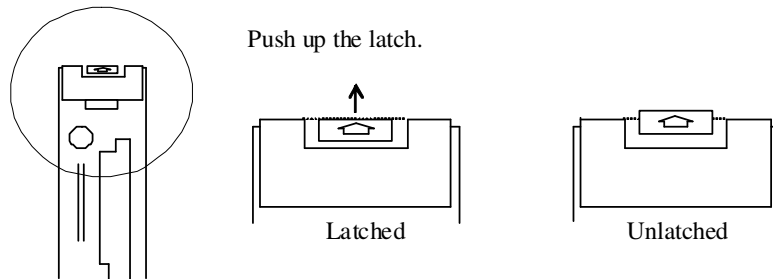

#### ⚠ CAUTION

Just disengage the latch. Do not push up the latch after the latch is disengaged. If you continue pushing up the latch forcibly, the latch can break.

- ③ Place a finger at the bottom of the front of the fan unit, and then push it up.

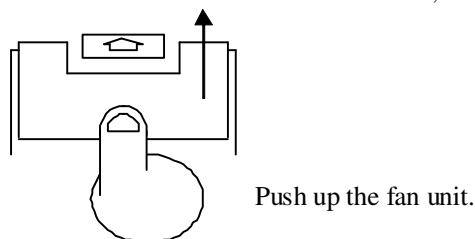

- ④ Push up the fan so that the fan unit is slanted by about 30 degrees.
- ⑤ Pull out the fan unit in the slanted direction.



- 4. Push up the fan motor so that it is slanted by about 30 degrees.
- 5. Pull out the fan motor in the slanted direction.

Attaching a fan unit

- ① Insert a fan unit deeply into the control unit at a slanted angle of about 30 degrees so that the fan unit touches the wall of the control unit.
- ② Lower the fan unit slowly on the control unit.
- ③ Push down the fan unit onto the near side to couple the fan unit with the top of the control unit.

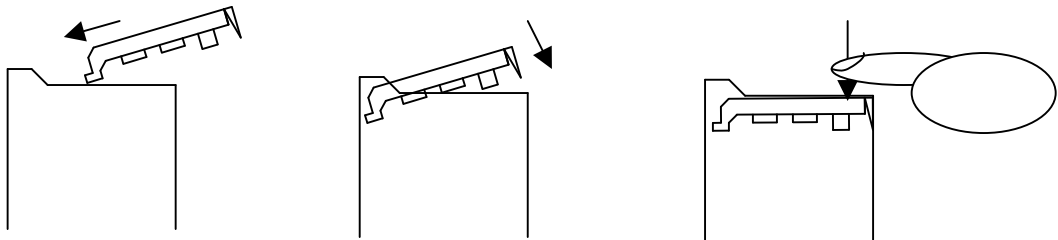

- 1. Insert the fan unit at about 30 degrees until it touches the far-side wall of the main unit.
- 2. Lower the fan unit slowly.
- 3. Push down the fan unit to connect it to the main unit.

**⚠ CAUTION**  
 The fan unit and main board are coupled directly with each other by the connector. When mounting the fan unit, failing to follow the connection procedure correctly may damage the coupling part of the connector.

- ④ Push down the latch at the top of the fan unit for latching.
4. Push down the latch.

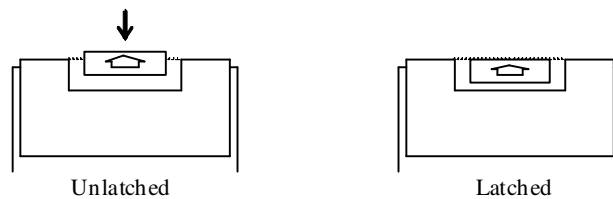

- ⑤ Turn on the power, then check that no fan alarm is issued and that both fans are rotating.

**⚠ CAUTION**  
 If the power is turned on without connecting the fan unit correctly, it is likely that the fan may not be able to rotate or a fan alarm may be issued even when it rotates. After replacement, make sure that the fan rotates normally and no fan alarm is issued.