

INSTALLATION CONDITION FOR UL RECOGNITION

- ② For UL recognition of the product, FANUC Series 30i/31i/32i-MODEL B Plus, Power Motion *i*-MODEL A
 ③ Plus and GALVANO SCANNER Controller *i*-A shall be installed after due considerations on UL requirements.

1. Environmental conditions

- Indoor use
- Altitude up to 1,000 m (Operating)
- Operating ambient temperature (The temperature inside the equipment):
 0 °C to 58 °C for LCD-mounted type
 0 °C to 55 °C for Stand-alone type
- Humidity (Operating): 75%RH or less, no condensation
- Use the equipment in Pollution degree 2 *1 environment or cleaner environment
 (*1: "Pollution Degree 2" is defined in the standard UL/CSA.)

2. Technical specifications

No.	Model	Input		Enclosure *2)	Remarks
		Volt	[A]		
1	A02B-0353-B500	DC24V	3.5A	Type 1	LCD mounted type
2	A02B-0353-B501				
3	A02B-0353-B502				
4	A02B-0356-B500				
5	A02B-0356-B501				
6	A02B-0356-B502				
7	A02B-0357-B500				
8	A02B-0357-B501				
9	A02B-0357-B502				
10	A02B-0358-B500				
11	A02B-0358-B501				
12	A02B-0358-B502				
13	A02B-0353-B802	DC24V	4.4A	Open Type	Stand-alone type
14	A02B-0353-B804				
15	A02B-0356-B802				
16	A02B-0356-B804				
17	A02B-0357-B802				
18	A02B-0357-B804				
19	A02B-0358-B802				
20	A02B-0358-B804				
② 21	A02B-0364-B500	DC24V	3.5A	Type 1	LCD mounted type
② 22	A02B-0364-B501				
② 23	A02B-0364-B502				
② 24	A02B-0364-B802	DC24V	4.4A	Open Type	Stand-alone type
② 25	A02B-0364-B804				
③ 26	A02B-0355-B802				
③ 27	A02B-0355-B804				

(*2. Open type, Type 1 - Open type and Type 1 are defined in the standard UL/CSA.

3. Power supply unit for the equipment must have a double insulation or reinforced insulation device from AC mains supply and the output voltage must be less than DC 60 V and Limited Energy Circuit. However, input voltage to the control unit shall not exceed DC 26.4 V.

(The insulation can be achieved with the use of an insulated DC power supply unit that complies with UL/CSA standard.)

4. Use the input power cable and the connector as following.

Housing: Tyco Electronics 1-178288-3

Contact: Tyco Electronics 1-175218-5

- ② Wire: Copper conductors 20AWG or thicker for LCD mounted type control unit, 16AWG or thicker for Stand-alone type control unit

5. If the equipment is used in a manner not specified by the manufacturer, the protection provided by the equipment may be impaired.

6. Equipment installation

6.1 The control unit and the peripheral units have been designed on the assumption that they are housed in closed cabinets. The cabinet should basically be made of metal.

6.2 Set up the LCD-mounted type control unit, the display unit, and the MDI unit on a flat surface of a Type 1 Enclosure.

6.3 Installing the LCD-mounted type control unit

Air is fed into the control unit from the bottom, drawn by the fan motors which are located on the top of the control unit.

Space (A), shown in the figure below, must be provided to ensure unrestricted air flow. Also, space (B) should be provided whenever possible. When space (B) cannot be provided, ensure that nothing is placed in the immediate vicinity which could obstruct the air flow.

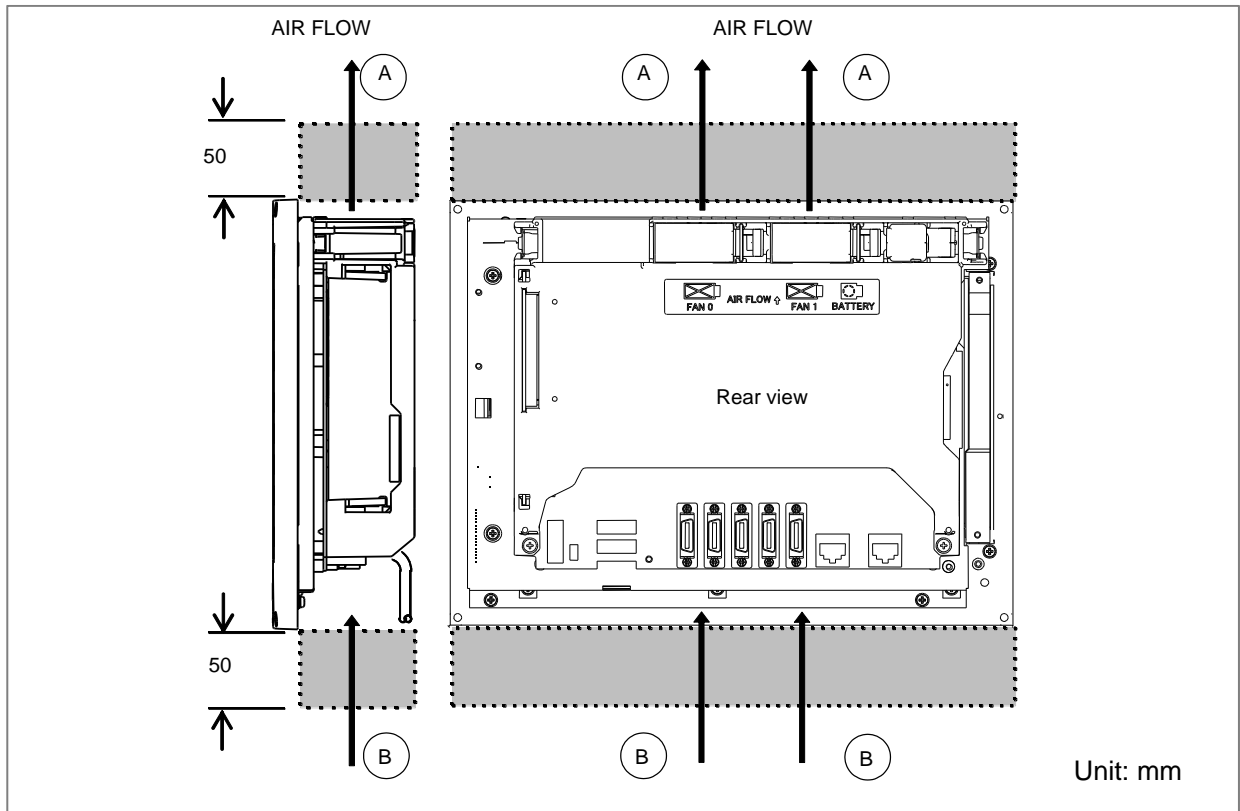

6.4 Installing the Stand-alone type control unit

Air is fed into the control unit from the bottom, drawn by the fan motors which are located on the top of the control unit. The spaces shown in the figure below (areas (A) and (B)) must be provided to ensure smooth air flow.

Also, adequate service access space is required in front of and at the top of the unit so that printed circuit boards and the fan motor can be replaced easily if necessary.

There is a spare connector located at the far end (at middle height) on the right side of the control

unit. This connector is used for control unit testing and other purposes. Therefore, space (area ©) for handling the connector is required.

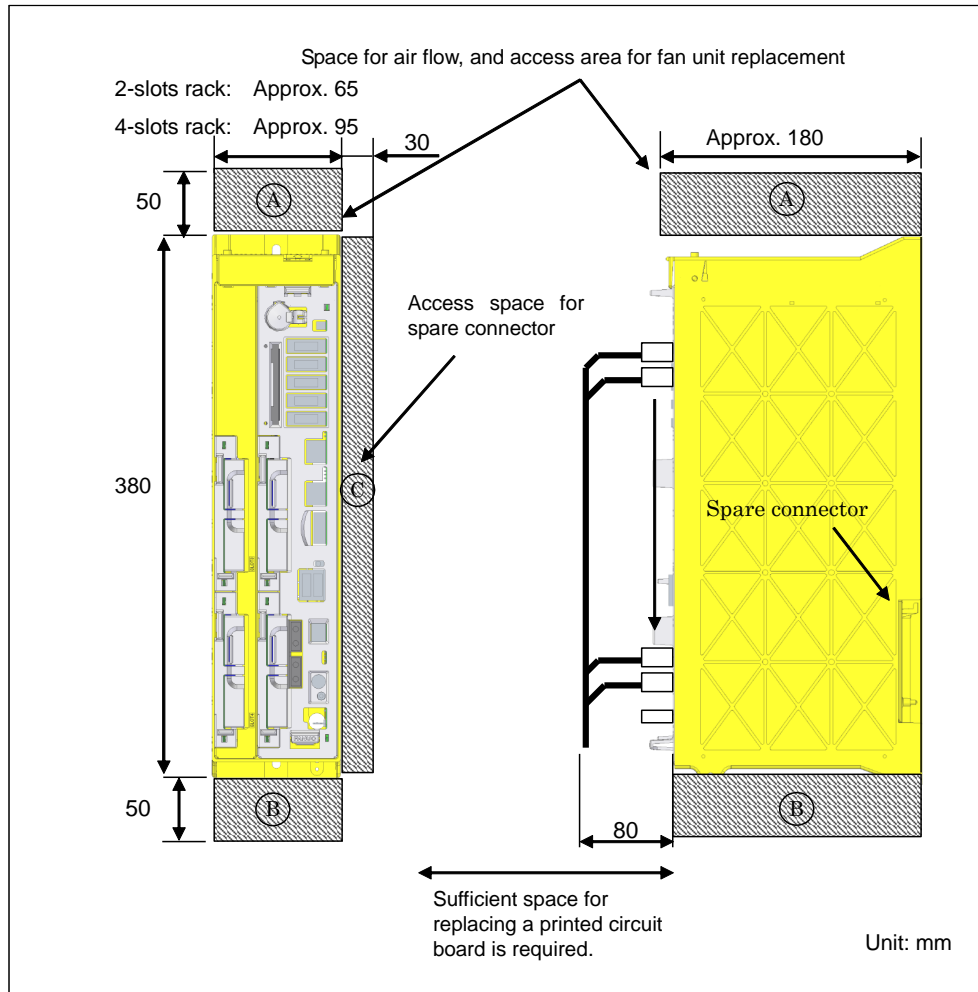

6.5 Connecting the Ground Terminal of the Control Unit

Connection between the ground terminal (which is marked with protective conductor terminal \oplus) of the control unit and 0 V.

⚠ CAUTION

In the control unit, the 0 V and the ground terminals are electrically connected to each other. So, do not connect any external unit's 0 V connected to the control unit's 0 V to any other line's grounding electrode that can have an electrical potential different from that of the grounding electrode connected to the control unit.

The following table lists the tightening torque for screws and nuts used to fasten the units (except those having molded mounting parts) explained herein and ground terminals in the units.

Screw and nut diameter	Tightening torque
M3	0.8 to 1.0 N·m
M4	1.6 to 2.0 N·m

The following table lists the tightening torque for screws and nuts used to fasten those units having resin parts, such as Stand-alone type control units.

Screw and nut diameter	Tightening torque
M4	1.1 to 1.5 N·m

M5	2.4 to 2.8 N·m
----	----------------

6.5.1 Connecting the ground terminal of a LCD-mounted type control unit
 Connect the 0 V line in the control unit to the cabinet's metal plate or signal system ground bar nearby via the ground terminal (see below).

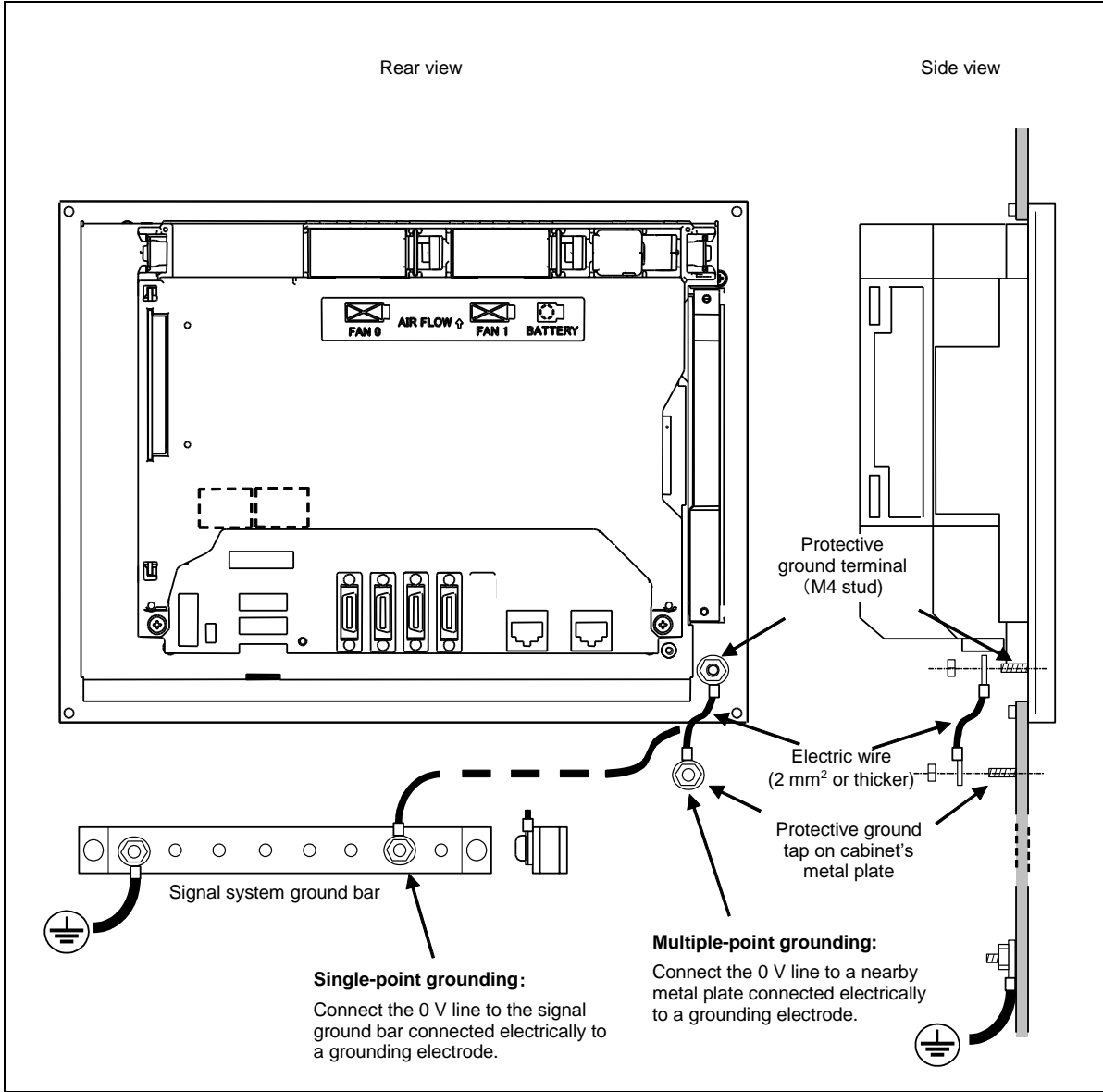

6.5.2 Connecting the ground terminal of a Stand-alone type control unit
 Connect an electronics circuit's 0 V line in the control unit to the cabinet's metal plate or signal system ground bar close to it via the signal ground terminals.
 Use the Faston terminal, FANUC specification: A02B-0166-K330.

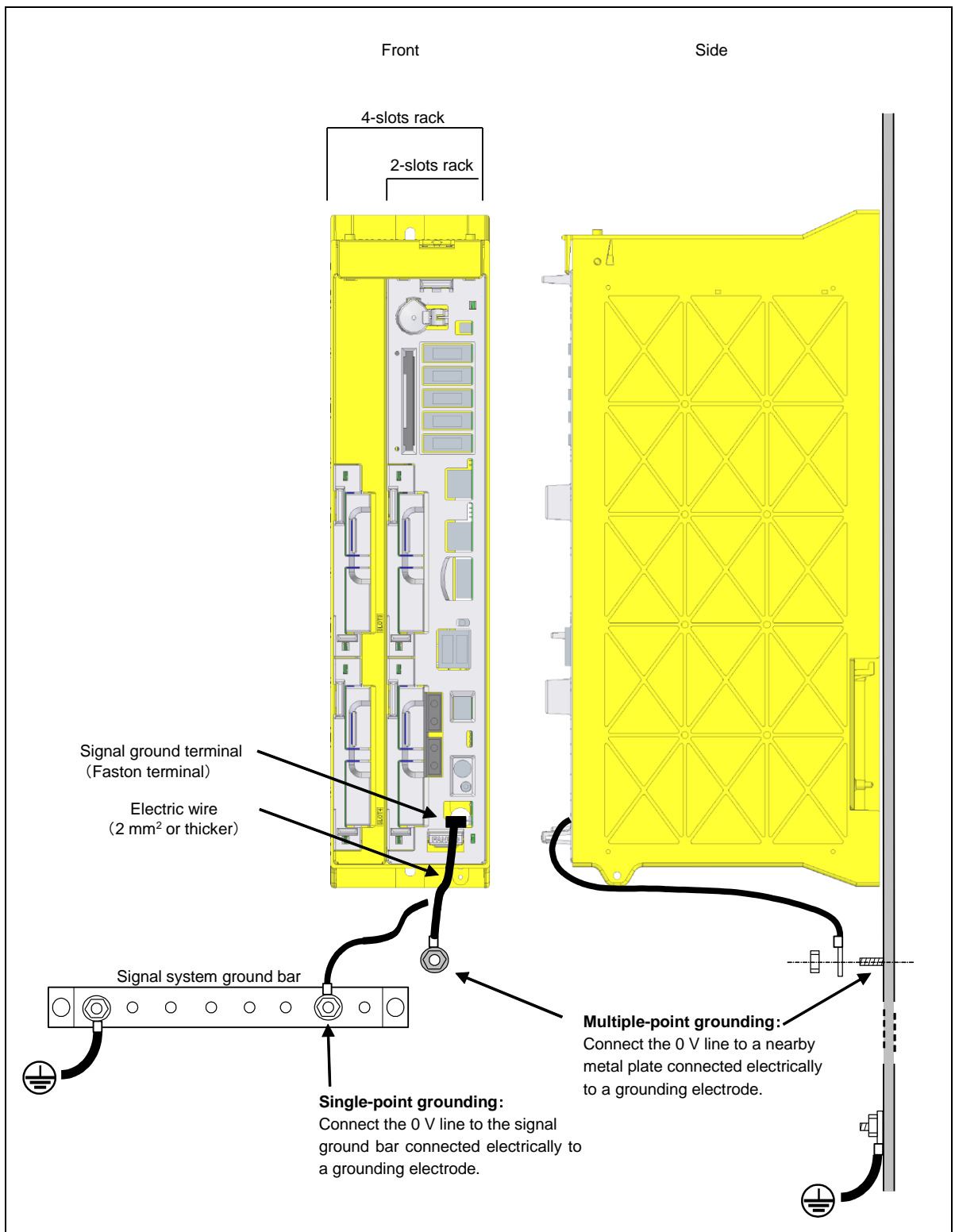

6.6 Outline drawings of units

Name		Panel cutout
LCD mounted type control unit Display unit for Stand-alone type control unit	10.4" LCD unit	Fig. U1
	15" LCD unit	Fig. U2
	19" LCD unit	Fig. U3
MDI unit	MDI unit (small type, 220x140mm)	Fig. U4
	MDI unit (ONG, 220x230mm)	Fig. U5
	MDI unit (ONG or QWERTY type A, 160x290mm)	Fig. U6
	MDI unit (QWERTY type B, 145x400mm)	Fig. U7
	MDI unit (QWERTY type C, 120x500mm)	Fig. U8
Stand-alone type control unit	2 slots	Fig. U9
	4 slots	Fig. U10

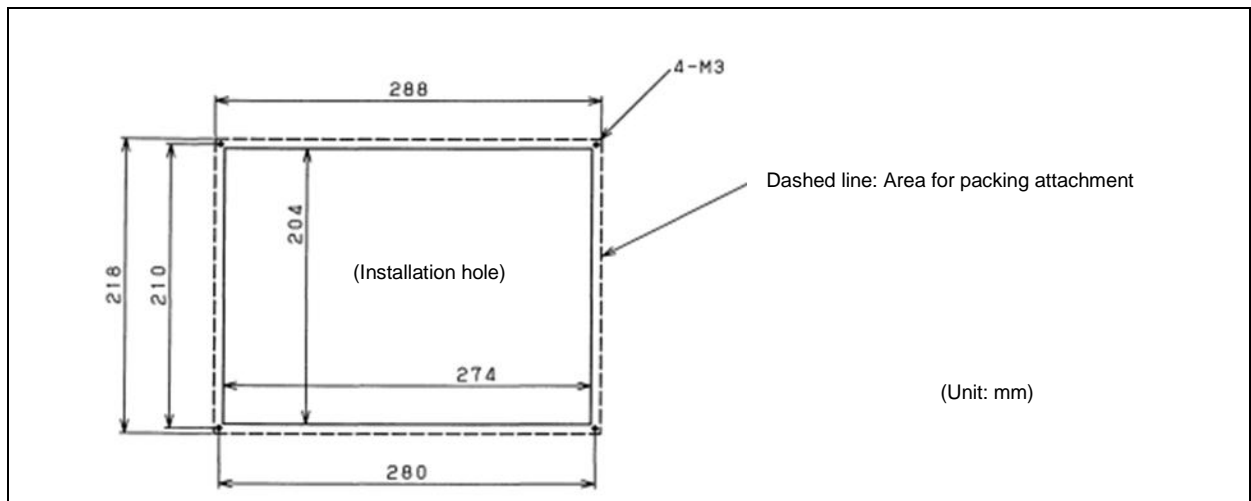

Fig. U1: 10.4" LCD unit

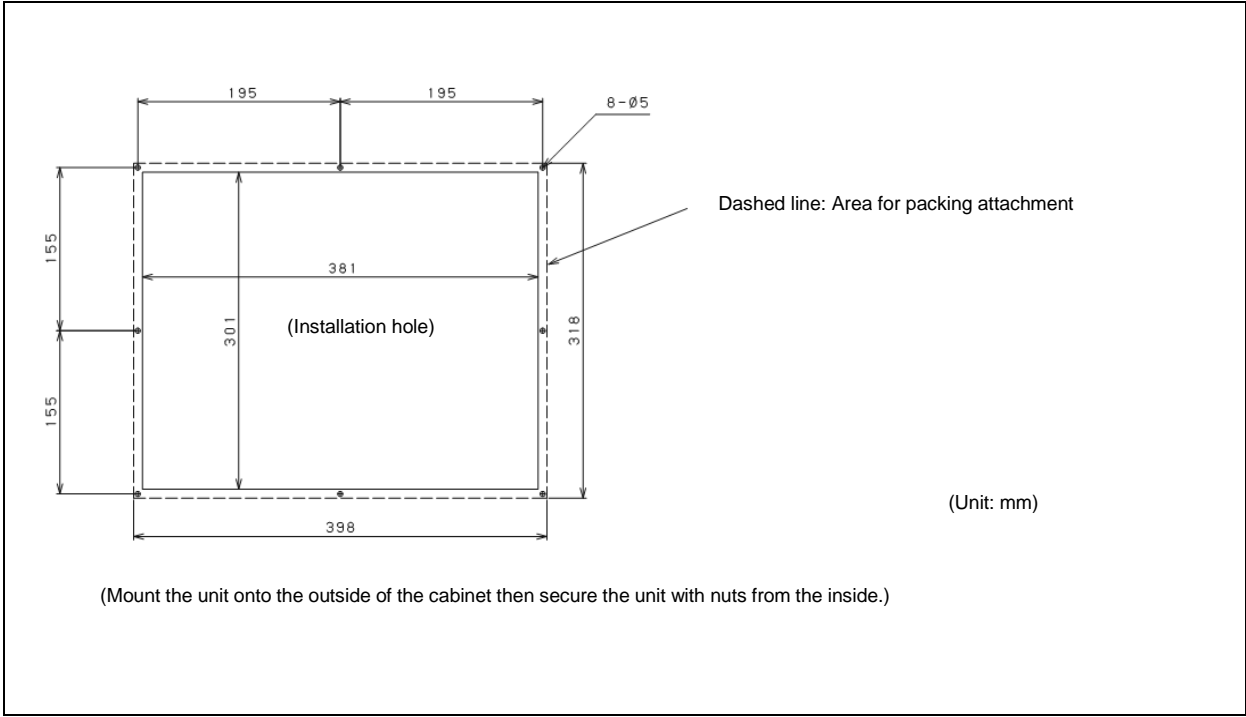

Fig. U2: 15" LCD unit

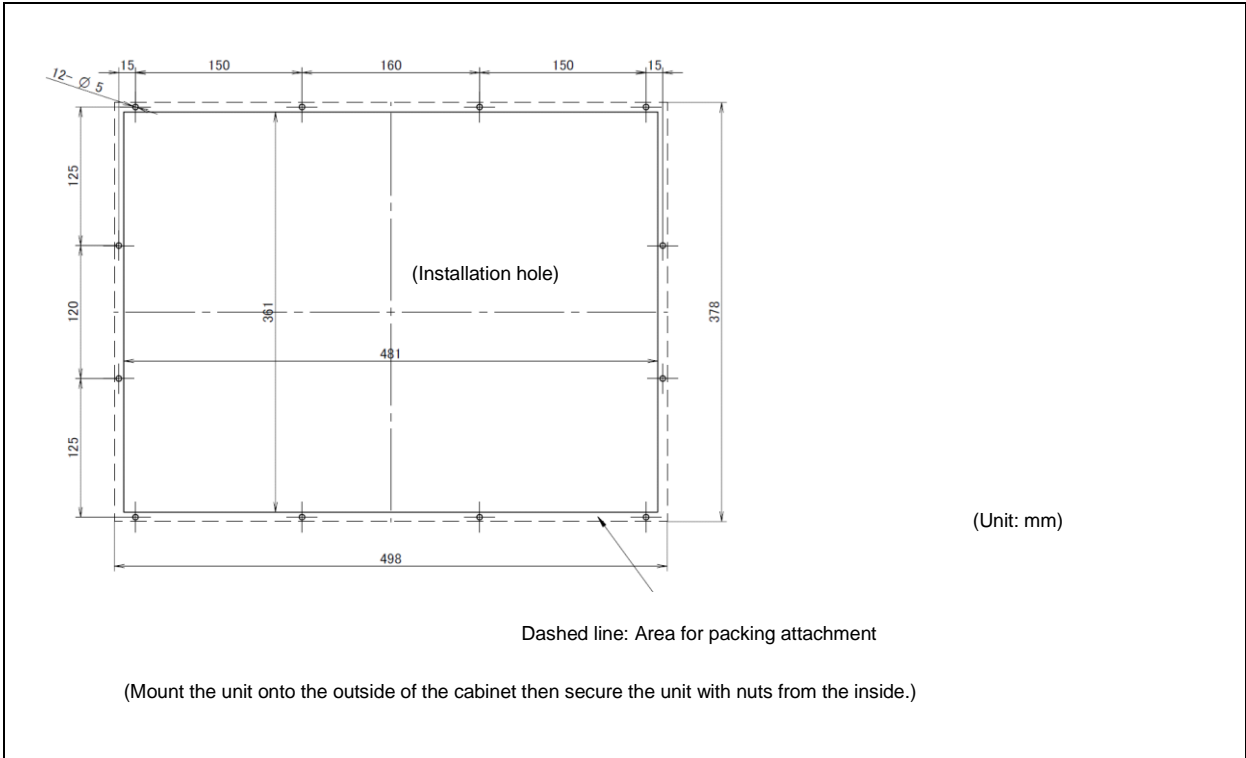

Fig. U3: 19" LCD unit

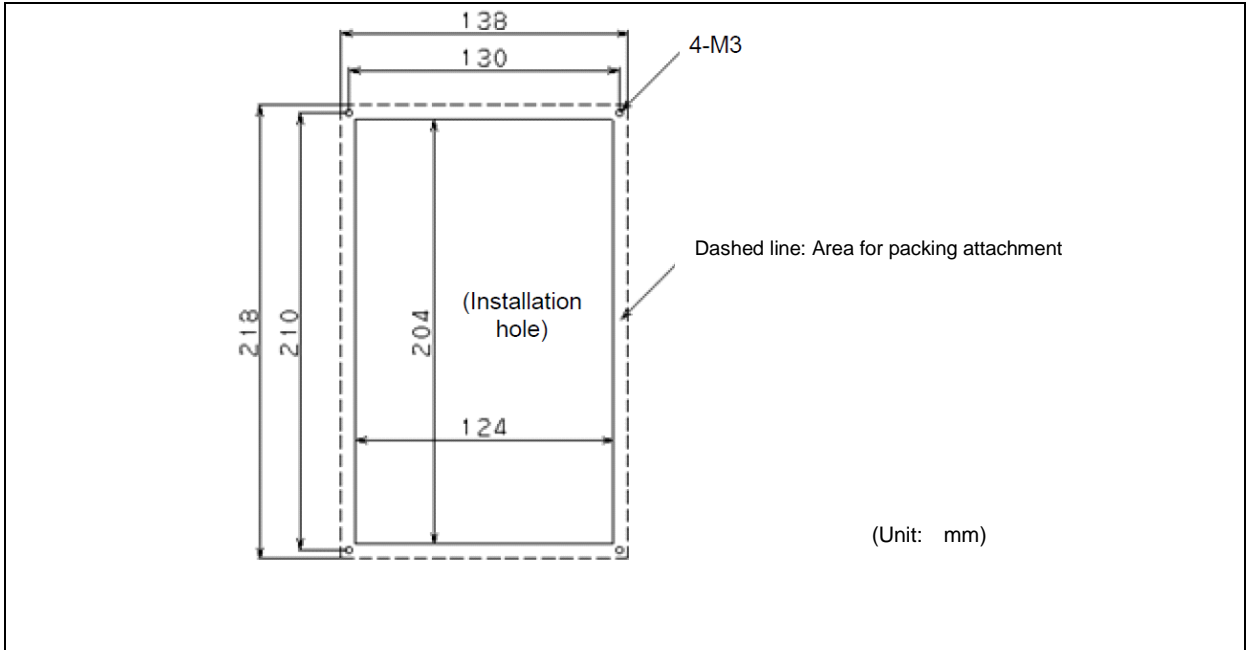

Fig. U4: MDI unit (Small type, 220x140mm)

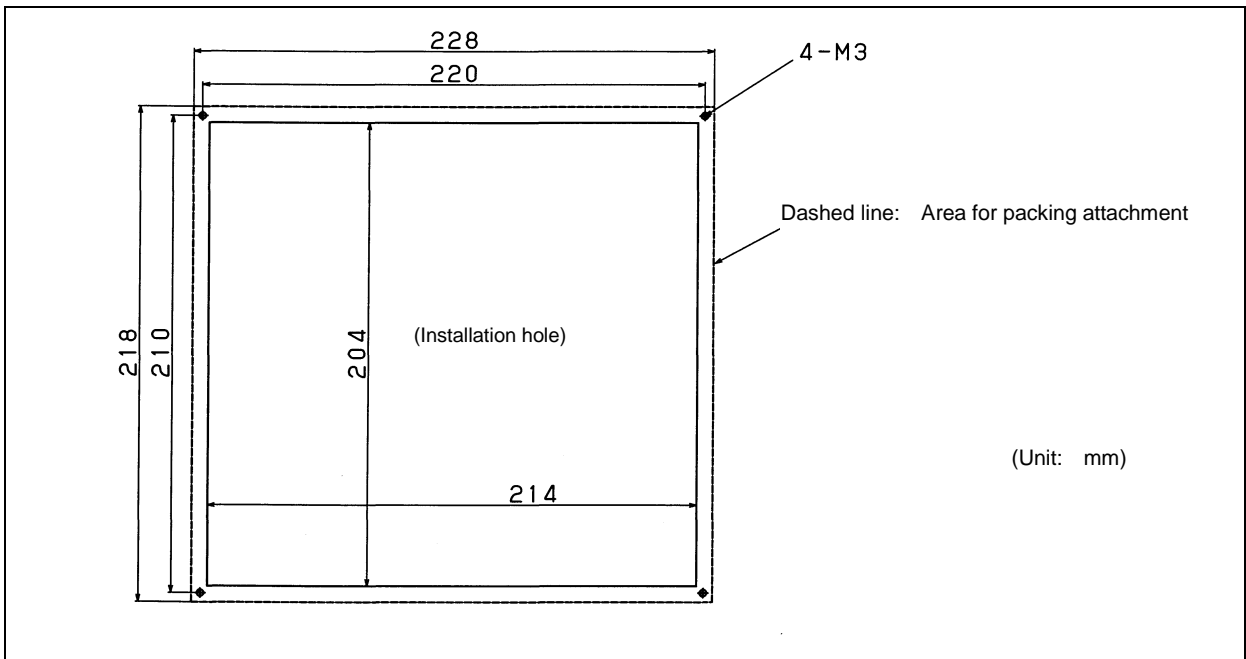

Fig. U5: MDI unit (ONG, 220x230mm)

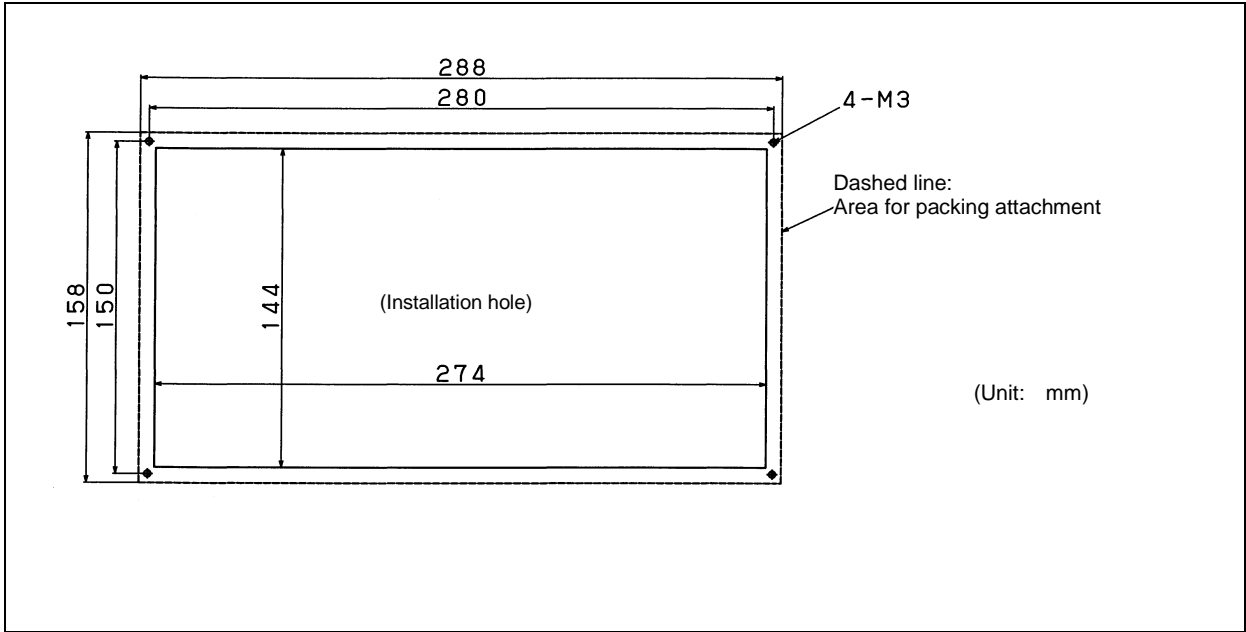

Fig. U6: MDI unit (ONG or QWERTY type A, 160x290mm)

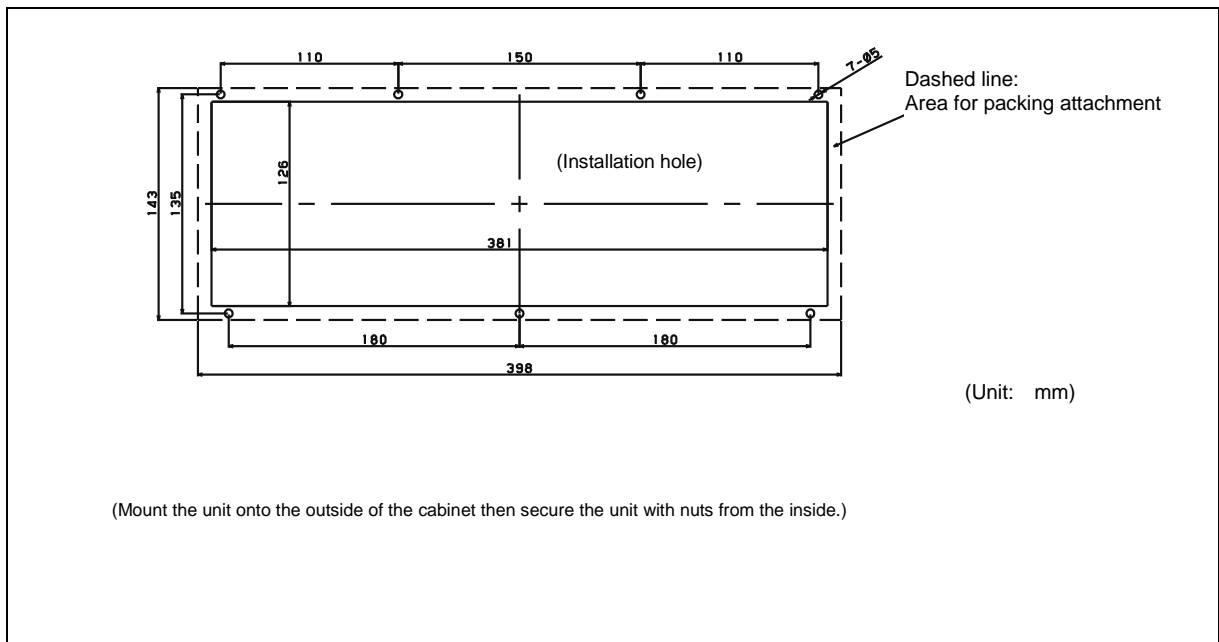

Fig. U7: MDI unit (QWERTY type B, 145x400mm)

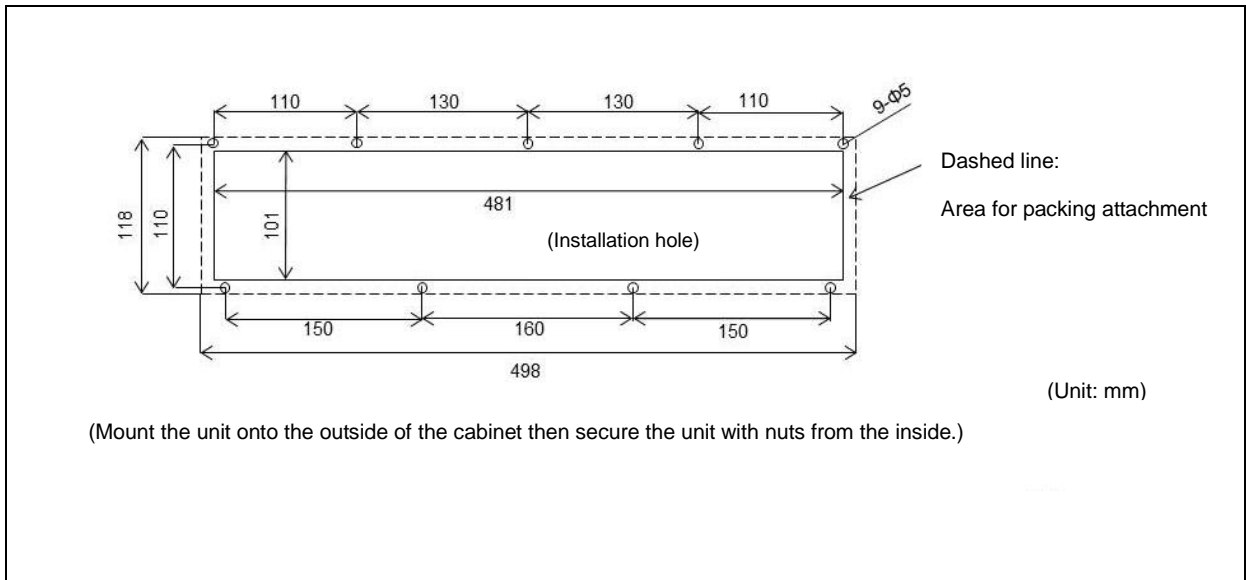

Fig. U8: MDI unit (QWERTY tupe C, 120x500mm)

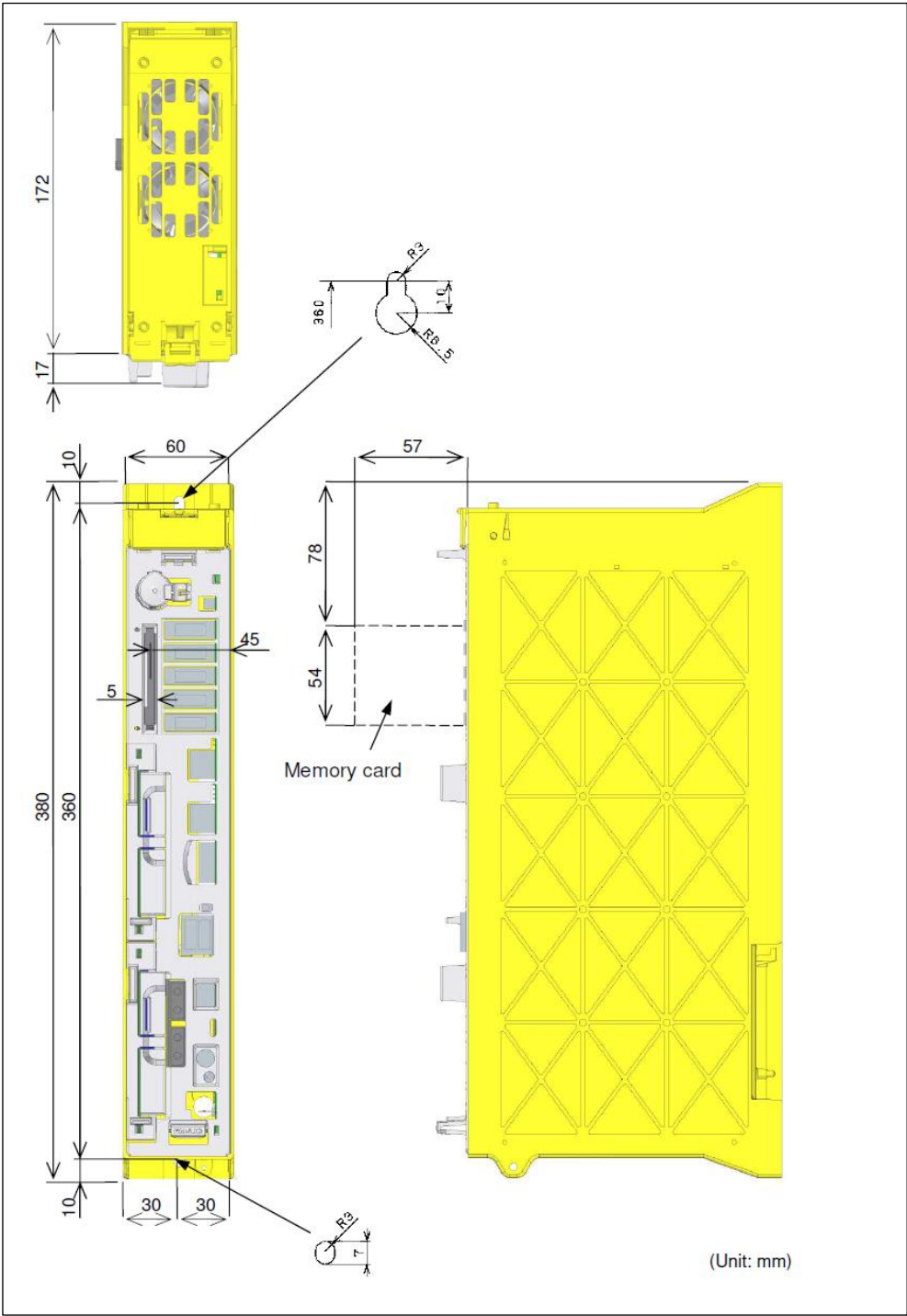

Fig. U9: Stand-alone type control unit (2 slots)

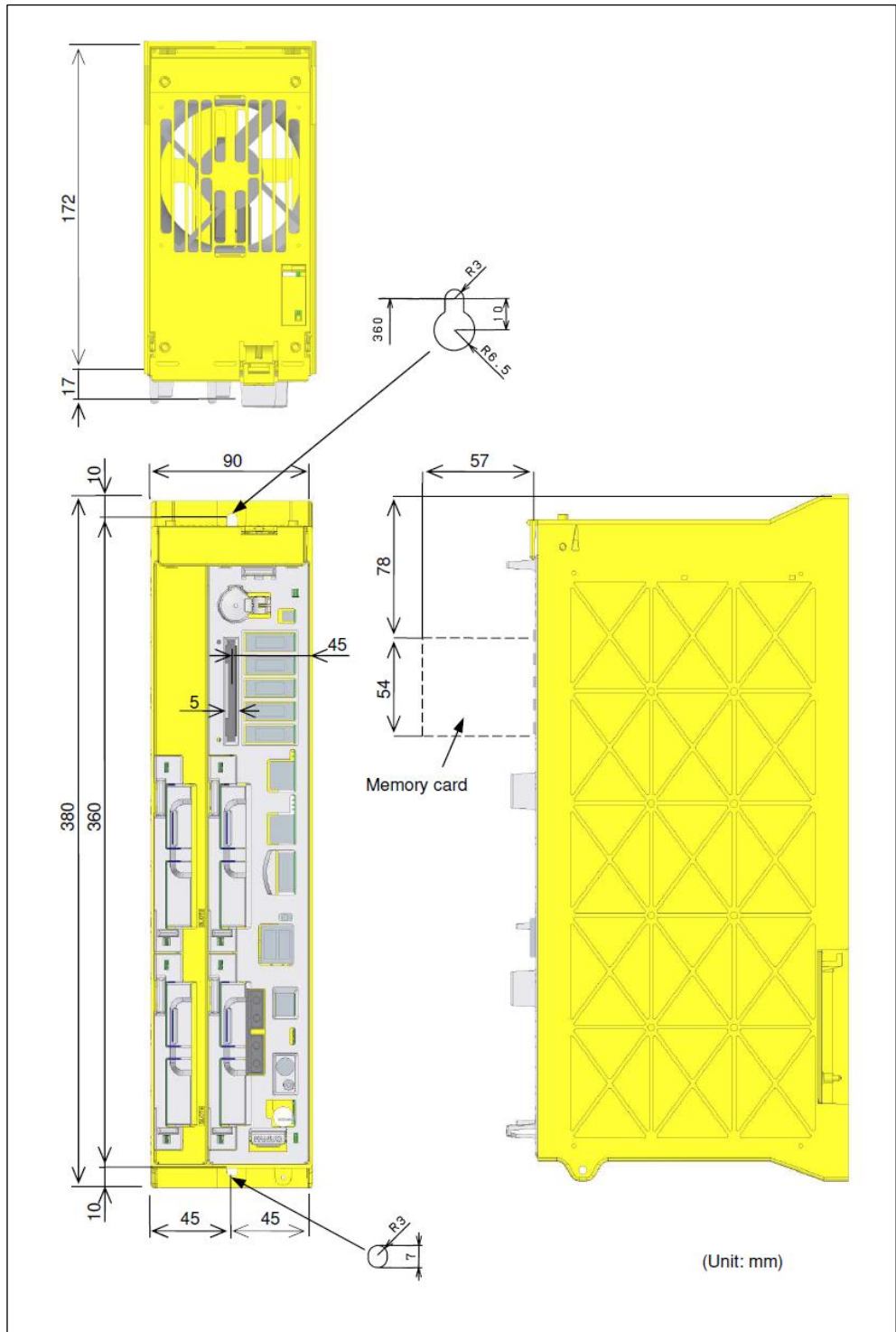

Fig. U10: Stand-alone type control unit (4 slots)

7. Replacing control unit maintenance parts

The maintenance of the control unit involves various danger. It must be undertaken only by a person who is trained in the related maintenance and safety requirements. Before replacing the control unit or its components, be sure to shut off externally supplied power.

7.1. Replacing fuses

⚠ WARNING
Before replacement of a blown fuse, its cause must be corrected. So, fuse replacement work must be done only by a person who is trained in the related maintenance and safety requirements.

NOTE
Replace the fuse only with the specified fuse purchased from FANUC. Order number of each fuse is shown below. Also, all fuses specified by FANUC are UL/cUL certified.

Fuse-mounting location of the LCD-mounted type control unit

10.4" LCD unit

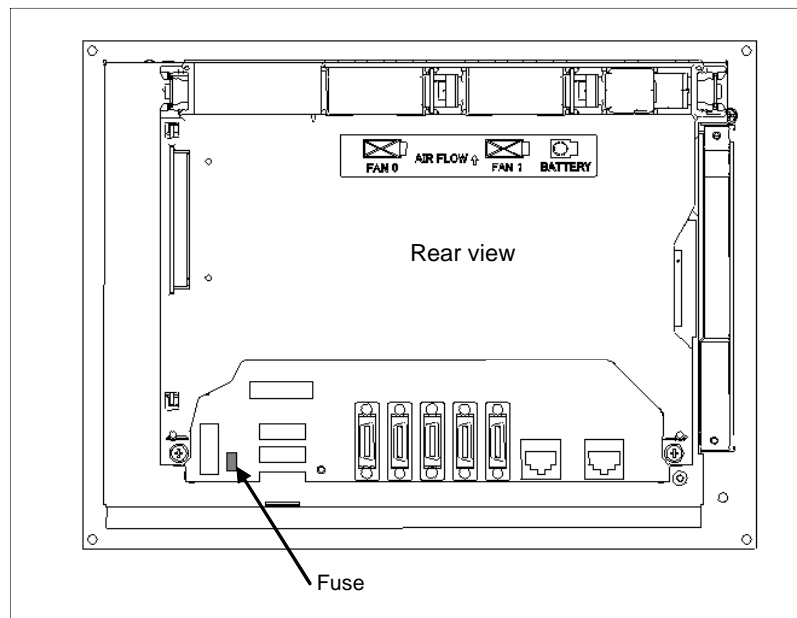

Fuse specification

Specification	Rating
A02B-0236-K100	48V AC/DC, 5A

LCD unit for PANEL iH (10.4" LCD unit, 15" LCD unit and 19" LCD unit)

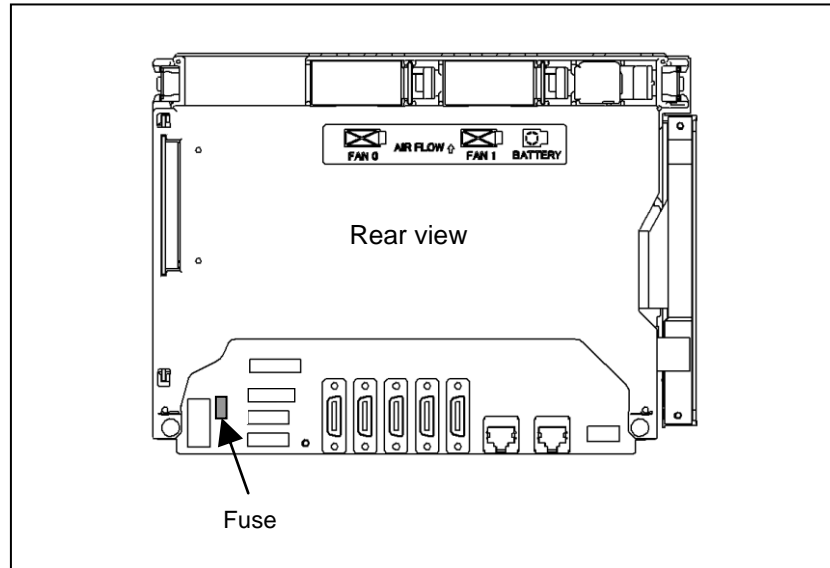

Fuse specification

Specification	Rating
A02B-0236-K100	48V AC/DC, 5A

Fuse-mounting location of the Stand-alone type control unit

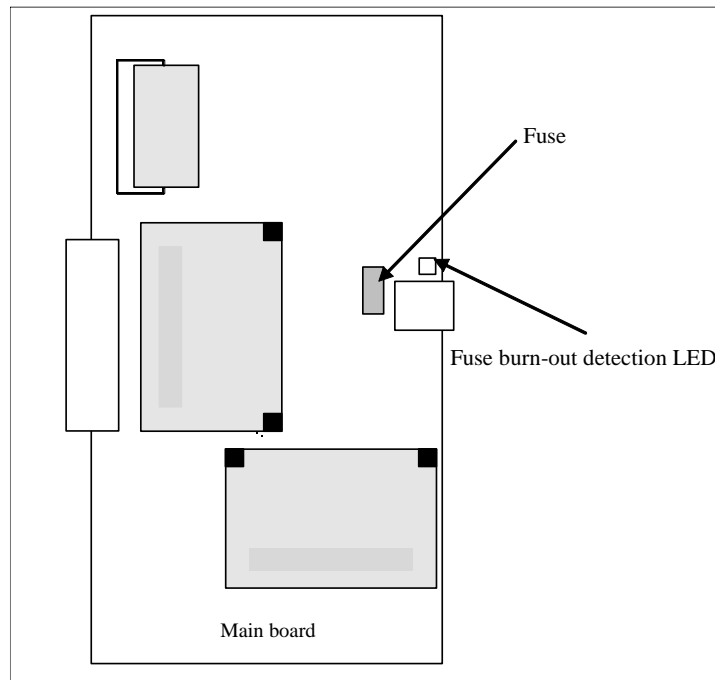

The fuse is on the main board. Before replacing the fuse, pull out the main board from the control unit.

Fuse specification

Specification	Rating
A02B-0265-K100	125V AC/DC, 7.5A

Fuse-mounting location of the Display Unit for Stand-alone type control unit
Display unit (10.4" LCD unit)

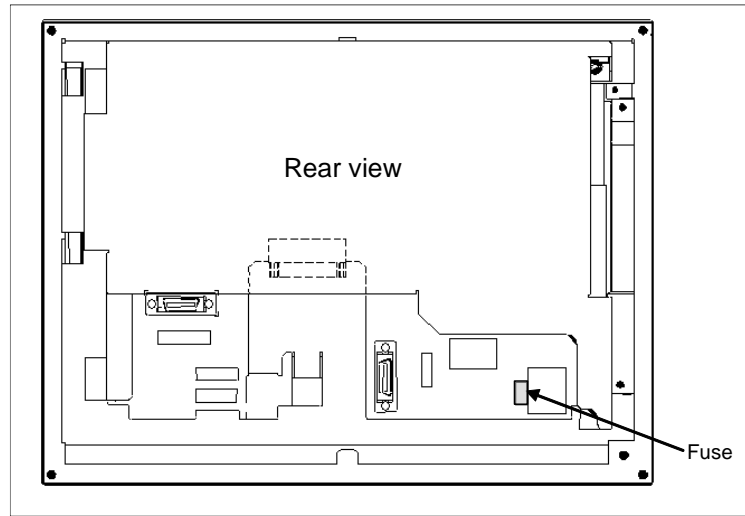

Fuse specification

Specification	Rating
A02B-0303-K101	48V AC/DC, 3.2A

Display unit for PANEL iH (10.4" LCD unit, 15" LCD unit and 19" LCD unit)

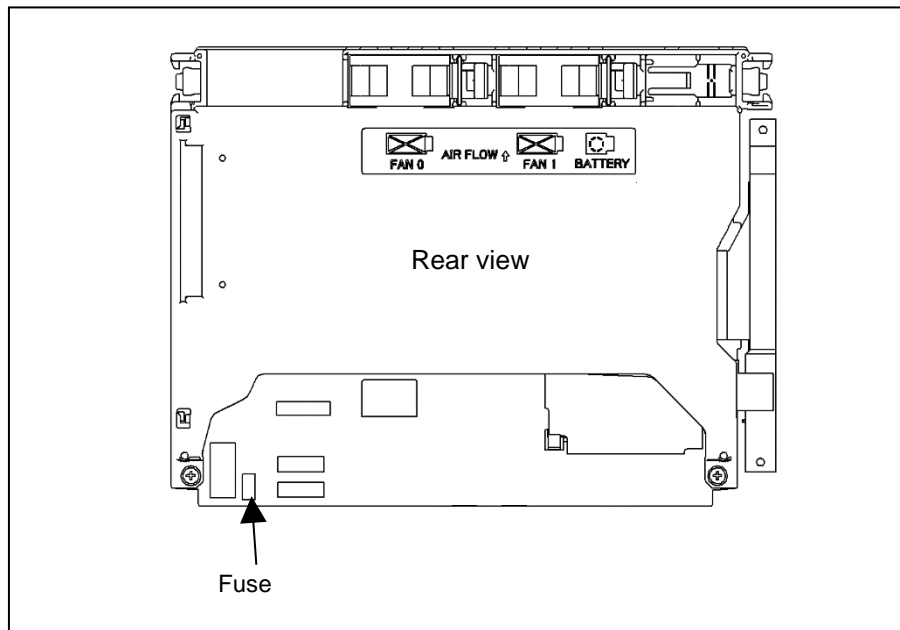

Fuse specification

Specification	Rating
A02B-0236-K100	48V AC/DC, 5A

7.2. Replacing the battery for memory backup in the control unit

For LCD-mounted type control unit

Prepare a new lithium battery (ordering code: A02B-0323-K102).

- 1) Turn the power to the machine (control unit) on. After about 30 seconds, turn the power off.
- 2) Pull out the lithium battery on the back of the control unit (Hold the latch of the lithium battery, and pull the lithium battery toward you while releasing the claw from the case).

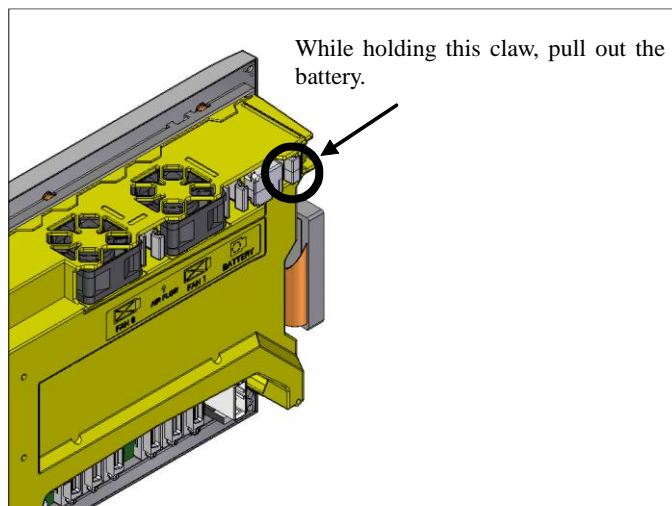

- 3) Put a new lithium battery into the control unit. (Push the battery so that the catch is latched with the case.) Confirm that the catch has been latched securely.

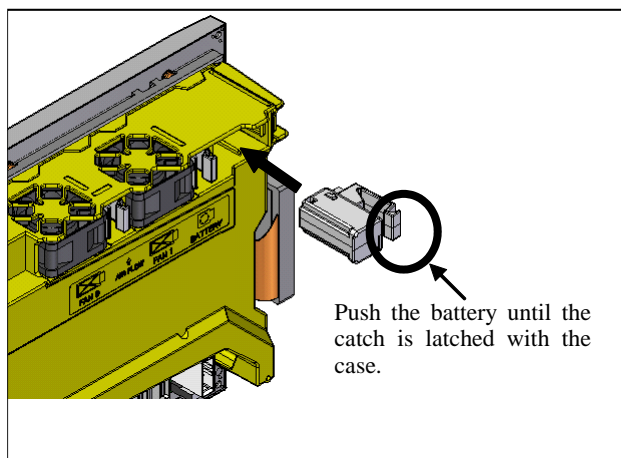

WARNING

Using other than the recommended lithium battery may result in the battery exploding. Replace the battery only with the specified lithium battery (A02B-0323-K102).

For Stand-alone type control unit

Prepare a new lithium battery (ordering code: A02B-0200-K102).

- 1) Turn the power to the machine (control unit) on. After about 30 seconds, turn the power off.
- 2) Remove the lithium battery on the upper section of the control unit.
First, unplug the connector by yanking the battery cable, and then take the battery out of its case.
The battery case is located in the upper section of the face plate of the main board.
- 3) Insert a new lithium battery and reconnect the connector.

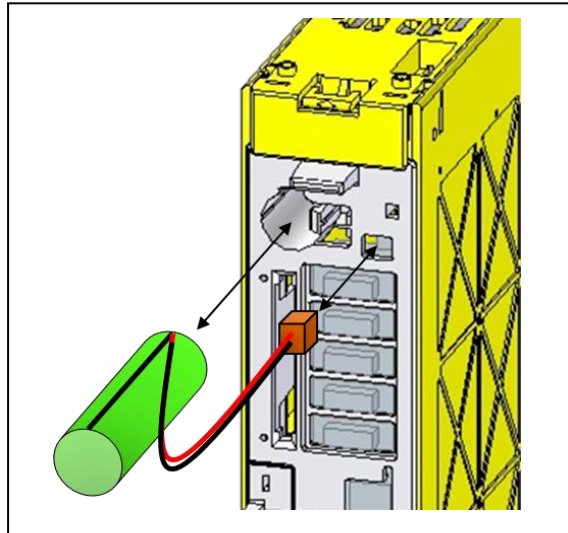

⚠ WARNING

Using other than the recommended lithium battery may result in the battery exploding. Replace the battery only with the specified lithium battery (A02B-0200-K102).

7.3. Replacing FAN motors

For LCD-mounted type control unit

- 1) When replacing the fan motor, be sure to turn off the power to the control unit.
- 2) Remove the fan motor from the case by holding fan motor's latch and pulling it out while releasing the claw from the case.
- 3) Put the fan motor into the case. After that, make sure that the fan motor's claw has latched the case securely.

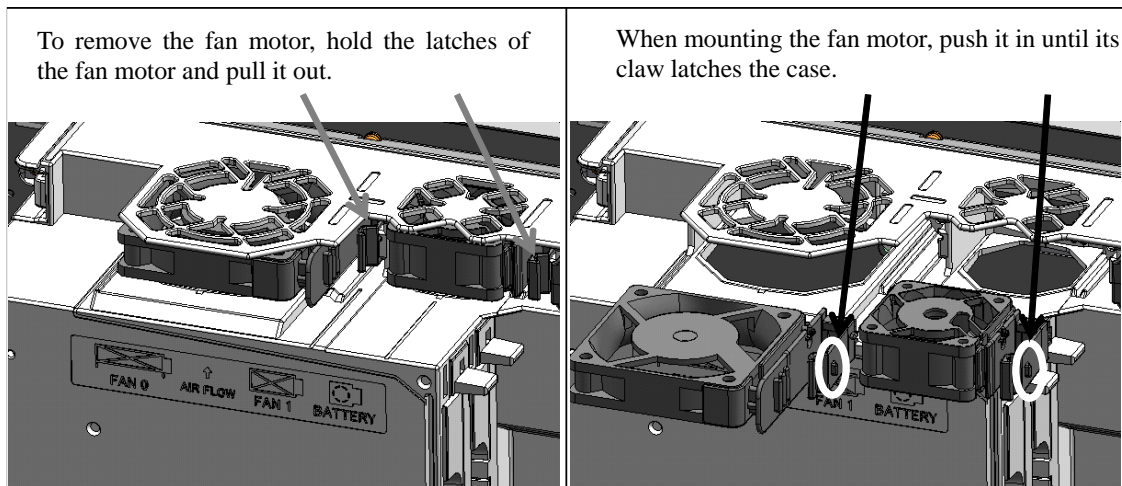

For Stand-alone type control unit

Detaching a fan unit

- 1) When replacing the fan unit, be sure to turn off the power to the control unit.
- 2) Push up the latch at the top of the fan unit so that the latch is disengaged.

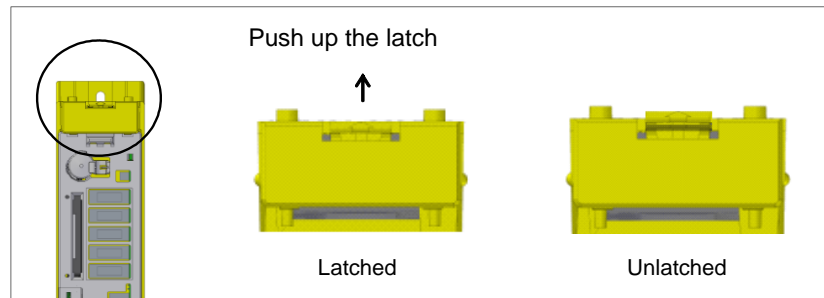

⚠ CAUTION

Just disengage the latch. Do not push up the latch after the latch is disengaged. If you continue pushing up the latch forcibly, the latch can break.

- 3) Place a finger at the bottom of the front of the fan unit, and then push it up.

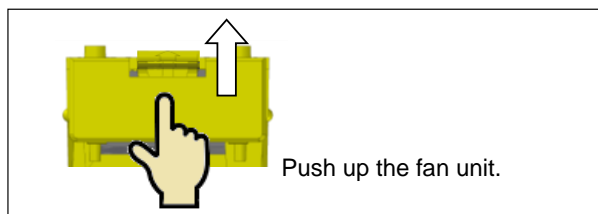

- 4) Push up the fan so that the fan unit is slanted by about 30 degrees.
- 5) Pull out the fan unit in the slanted direction.

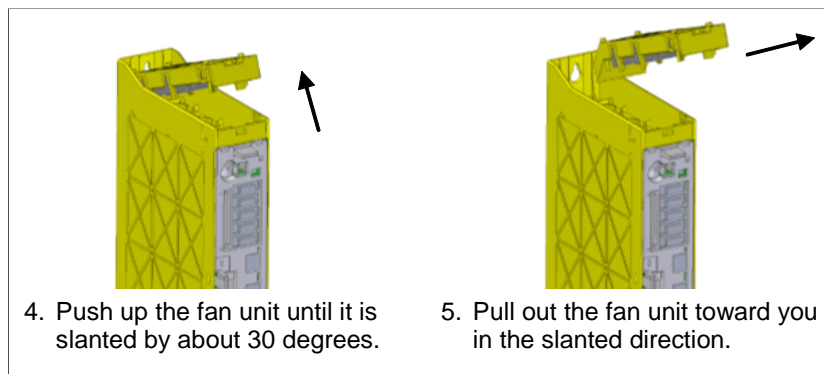

Attaching a fan unit

- 1) Insert a fan unit deeply into the control unit at a slanted angle of about 30 degrees so that the fan unit touches the wall of the control unit.
- 2) Lower the fan unit slowly on the control unit.
- 3) Push down the fan unit onto the near side to couple the fan unit with the top of the control unit.

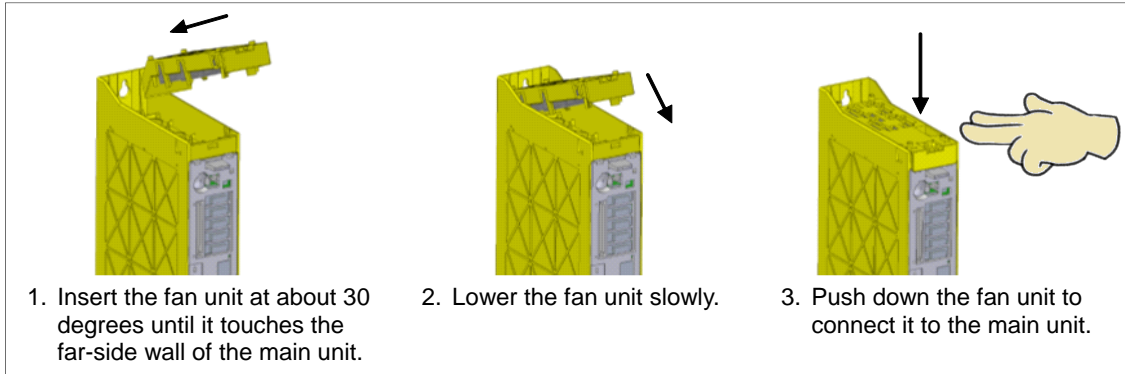

CAUTION

The fan unit and main board are coupled directly with each other by the connector. When mounting the fan unit, failing to follow the connection procedure correctly may damage the coupling part of the connector.

- 4) Push down the latch at the top of the fan unit for latching.

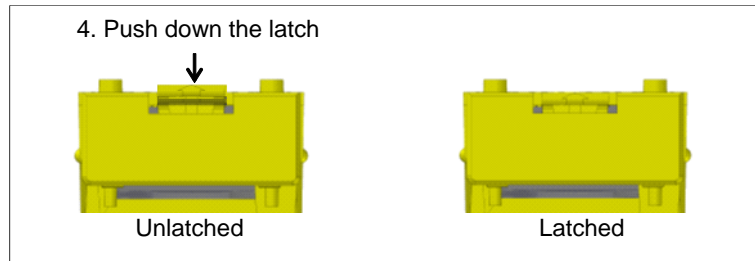

- 5) Turn on the power, then check that no fan alarm is issued and that both fans are rotating.

CAUTION

If the power is turned on without connecting the fan unit correctly, it is likely that the fan may not be able to rotate or a fan alarm may be issued even when it rotates. After replacement, make sure that the fan rotates normally and no fan alarm is issued.

Edition history:

Ed.	Date	Descriptions
01	2020/02/04	The first edition registration
02	2022/08/02	- Addition of Power Motion i-MODEL A Plus - Error correction of wire size of input power cable
03	2025/07/11	Addition of GALVANO SCANNER Controller i-A