

**FANUC**

**CORPORATE PROFILE**

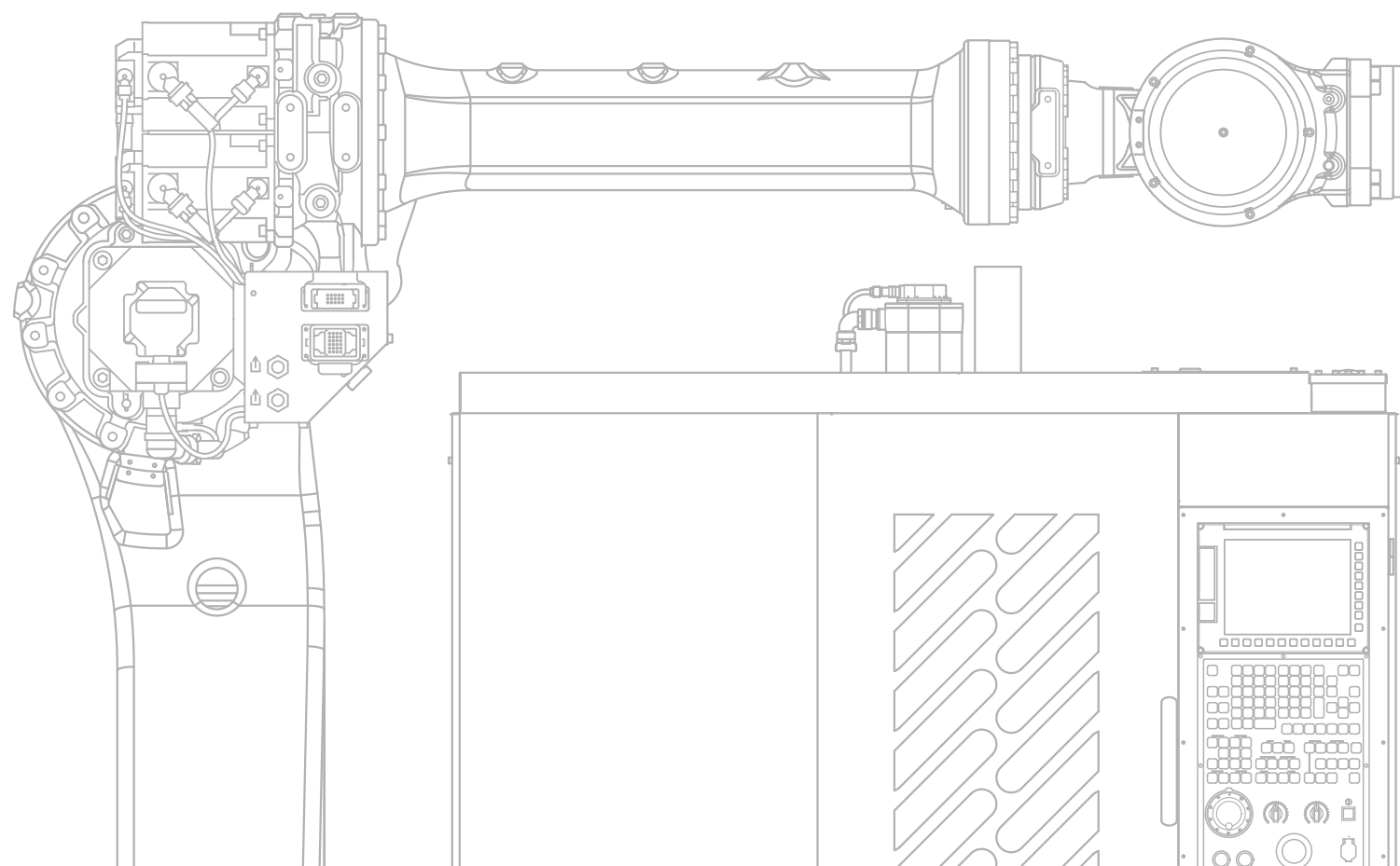

# With our automation technology FANUC will join you on your journey towards a successful business

FANUC continues to pursue technologies which are required for the future of industrial automation through the FA business for machine control, the ROBOT business and the ROBOMACHINE business to which the basic FA technologies are applied.

No stops. Smoother. Faster. More sophisticated.  
Less noise and energy saving as well.

FANUC continues to support your ever-changing business by pursuing automation.

## Message from the President and CEO

FANUC has consistently pursued industrial automation across manufacturing and other industries, ever since its beginnings as a project team for developing controls in 1955, proceeding to the successful development of the first NC (numerical control) and servo mechanism in the private sector in 1956.

We conduct the FA (Factory Automation) business based on these basic technologies, as well as the ROBOT business and ROBOMACHINE business to which these basic technologies are applied. In order to keep providing more value to our customers going forward, we actively develop and implement the latest technologies, including those for control, digital, IoT, and AI, especially focusing on the following points:

- Abiding by our slogan, "one FANUC," we make the most of our unique strengths; the provision of total solutions that combine the FA, ROBOT, and ROBOMACHINE businesses as well as SERVICE, and support of global customers by our Group unified as one.
- Based on our original stance that FANUC is a supplier of capital goods, reliability has top priority. To minimize customers' downtime and improve operating rates, we are thorough in being "Reliable, Predictable, Easy to Repair," in product development.
- We practice "Service First" by providing advanced maintenance services adhering to our global standards anywhere in the world, and continue to offer maintenance as long as customers continue to use our products.

We aim to remain a trusted company in the field of industrial automation which has great potential for growth, by promoting automation and efficiency in our customers' business.

Kenji Yamaguchi  
Representative Director, President and CEO

## Basic Principles of FANUC



A company will last forever and be sound with strict preciseness.  
The corruption of an organization and downfall of a company start  
from a lack of transparency.

## Vision

To provide indispensable values throughout the world  
in the field of industrial automation  
through unceasingly creating technological innovations,  
and to continue to be a company that is trusted by stakeholders.

# FANUC's Automation Technology that Supports Industries Around the World

FANUC has consistently pursued industrial automation across manufacturing and other industries ever since its beginnings in 1955. The products we have created are operating in shop floors around the world, supporting our daily lives. Industrial automation is a field that has high potential to evolve. To realize this evolution, we are committed to further advancing our technology.

Basic Products

## FA

FANUC provides basic products to introduce industrial automation, such as CNCs to control the operation of machine tools using numerical information, and servos to control speed and position.



Fitted to machines by machine tool builders

## ROBOT

Various tasks can be automated by applying the basic technologies of CNCs and servos to freely control robot arms. Work environments are improved by releasing workers from dangerous, dirty, and difficult jobs, and product quality is enhanced and stabilized through long hours of steady and continuous production. Furthermore, by developing robots that can work in collaboration with humans, the shrinking workforce can be compensated. In such a manner, FANUC contributes to improving productivity and operating rates in industries worldwide.



Applied Products

## ROBOMACHINE

FANUC develops compact machining centers (ROBODRILL), electric injection molding machines (ROBOSHOT), and wire electrical discharge machines (ROBOCUT) to which the basic technologies of CNCs and servos are applied. We contribute to improving our customers' productivity by pursuing improvements in machining/molding performance and operating rates, along with ease of use.



FANUC products are used in production/logistics lines, supporting operations such as the manufacturing of everyday goods.



Aerospace



Electronics



Food

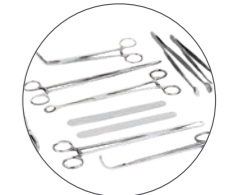

Medical equipment



Plastic parts



Automobile



Logistics

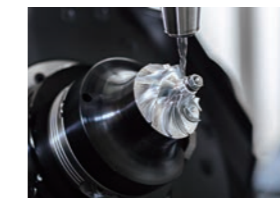

### 5-axis machining with CNC

High-precision and reliable CNC system control makes 5-axis machining efficient, and enables the production of complicated parts. Advanced control technologies that realize simultaneous multi-axis high-speed driving and high-precision smooth machining are used to produce molds and electrodes.



### Various Assembly with ROBOTS

ROBOTS have been introduced in a variety of production processes, such as assembly, screw tightening, parts mounting, transfer, and inspection. FANUC offers a wide lineup from compact high-speed robots to large robots, to promote automation in any kind of process.



### Multi-Material Molding with ROBOSHOT

Along with standard molding, a wide variety of injection molding technologies, such as insert molding and overmolding, as well as a sophisticated automation system, contribute to the production of automobiles. Multi-material molding is a technology that combines and molds different materials using a single mold, making it possible to produce hybrid parts that have many different characteristics.

## FANUC's Development Structure

FANUC believes that high reliability leads to the enhancement of our customers' productivity and competitiveness. For this reason, FANUC designs products with reliability in mind from the development stage.

### FANUC's Development Policy

Our origins embrace the stance that FANUC is a supplier of capital goods. Therefore, in order to minimize downtime and improve the operating rate for our customers, we are thorough in being "Reliable, Predictable, Easy to Repair," in product development.

*Reliable*  
*Predictable*  
*Easy to Repair*



**Our development and manufacturing departments work closely together to provide high-quality products.**

One of FANUC's most important characteristics is that the development and manufacturing departments communicate with each other on a daily basis. This allows our product design engineers to gain a thorough knowledge of the manufacturing process.



### Next Generation Technology Laboratory

The Next Generation Technology Laboratory brings together researchers from the Research & Development Divisions of each product line to engage in research and development of underlying technologies which will be required in a few years, in a one FANUC scheme that transcends divisions.



Reliability Evaluation Building

### System to Enhance Reliability

The Reliability Evaluation Building is the largest building for research and development. A large number of evaluation tests are conducted simultaneously under more severe conditions than in actual conditions, in order to efficiently improve the reliability of our products.

#### Product Test Area



In this area which comprises the major part of the Reliability Evaluation Building, the reliability of products is thoroughly validated through accelerated life tests. Considering that test results will be inconsistent, the number of samples is increased and tests are conducted under various conditions, in order to ensure the long-term reliability of FANUC products.

#### Test Rooms for Specific Purposes

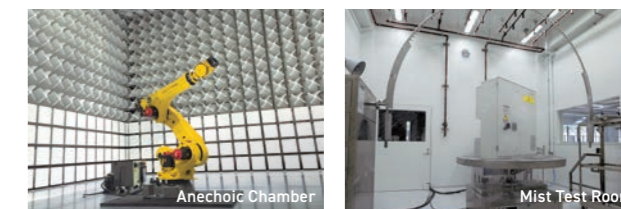

There are test rooms dedicated to specific purposes, such as an anechoic chamber, an EMS (electromagnetic susceptibility) test room, a vibration test room, a mist test room, a variable temperature room, a variable humidity room, a capability limit test room, a noise measurement room, a submergence test room, a cleanroom, and a precision measurement room.

## FANUC's Manufacturing Sites

FANUC produces its products in Japan so that development and manufacturing are consolidated. To ensure BCP (business continuity planning), there are multiple production lines at four bases to cope with natural disasters or other incidents.

### Headquarters Factories

#### Oshino-mura, Yamanashi Prefecture

Factories in the Headquarters campus in Oshino-mura, Yamanashi Prefecture. Many factories are dispersed in the 1,780,000 square meter FANUC forest, rich in nature. Factories include those for CNC, Servo Amplifier, Servo Motor, ROBOT, ROBOSHOT, and ROBOCUT assembly. There are also Machining, Press, Die Cast and Paint factories. Factory automation and robotization are actively promoted, as can be seen in the achievement of long hours of continuous unmanned machining.



### Mibu Factories

#### Mibu, Tochigi Prefecture

These are the most advanced factories built on 700,000 square meters of land in Mibu, Tochigi Prefecture. The factories are highly automated with all devices being connected to a network. Each process is automated with robots, and connected with an automatic transport system. Entire production, from machining parts to final assembly and testing, is conducted here. The production capacities of CNCs, Servo Amplifiers, and Servo Motors of the factories in Mibu as well as FANUC Headquarters have been increased to ensure stable supply. ROBOT controllers are also manufactured in Mibu.



### Tsukuba Factories

#### Chikusei, Ibaraki Prefecture

The Tsukuba Factories lie in the 900,000 square meter area in Chikusei, Ibaraki Prefecture. In Tsukuba Area 1, ROBODRILLS and ROBOTS are assembled. In Tsukuba Area 2, parts for ROBODRILLS and ROBOTS are machined and assembled. ROBOT controllers are manufactured in Area 2 as well. The high level of robotization in these factories greatly increases efficiency in production.



Tsukuba Area 1



Tsukuba Area 2

### Hayato Factories

#### Kirishima, Kagoshima Prefecture

The Hayato Factories are located in the 170,000 square meter area in Kirishima, Kagoshima Prefecture. Sensors for Servo Motors are manufactured in the highly robotized facilities.



# FANUC's Factories

We leverage our own products, such as ROBOTS, for advanced automation and efficient production in many factories.

## CNC Factory

Headquarters Mibu

Many FANUC ROBOTS are utilized for complicated assembly tasks which only humans could perform in the past.



## SERVO MOTOR Factory

Headquarters Mibu

The latest robotized factory, consolidating FANUC's technologies, boasts a high level of automation in retrieving parts, assembling, testing, and packaging, leading to efficient production.



## SERVO AMPLIFIER Factory

Headquarters Mibu

All processes are automated with FANUC ROBOTS, from the assembly of components such as printed circuit boards, heat radiation fins, and cooling fans into enclosures, to conducting testing.



## ROBOT Factory

Headquarters Tsukuba

ROBOTS are manufactured in automated assembly systems, where a large number of FANUC ROBOTS are used to make ROBOTS. Assembled ROBOTS are transported automatically to the test area, where they are subject to automatic testing, continuous operation, and inspection before shipment.



## ROBODRILL Factory

Tsukuba

Units such as tool changers are assembled automatically by ROBOTS. Many collaborative robots are actively used to assemble spindles alongside human workers.



## ROBOSHOT Factory

Headquarters

Workers assemble heavy units in cooperation with collaborative robots. Collaborative robots are also used for applying anti-rust oil and washing, thus streamlining manufacturing.



## ROBOCUT Factory

Headquarters

Heavy parts are assembled jointly by workers and collaborative robots. Progress of assembly and testing are monitored in real-time, and instructions for the tasks to be performed are provided appropriately according to the process.



## Machining Factory

Headquarters Tsukuba

Parts for ROBOTS, ROBODRILLS, ROBOSHOTS and ROBOCUTS are machined in this factory. With the installation of FANUC ROBOT cells, unmanned operation is possible for long hours, including during nights and weekends. The operating status of machine tools and ROBOTS are monitored to improve the operating rate, and changes in accuracy are also detected, resulting in the decrease of defects in machining. Furthermore, to maintain a consistent factory environment, the mist amount, temperature and illuminance are visualized.

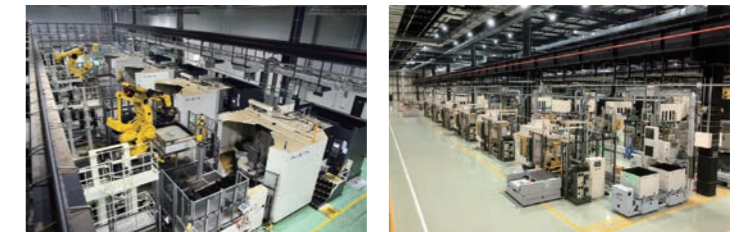

## SERVO MOTOR Parts Machining Factory

Headquarters Mibu

Parts for motors are manufactured with CNC lathes. The workpieces are supplied to machining cells by an automated warehouse, then automatically loaded and unloaded by ROBOTS.



## Press Factory

Headquarters Mibu

Pressed parts for motors are produced here. ROBOTS are used to automatically take out, inspect, and measure pressed parts.



## Die Cast Factory

Headquarters Mibu

Die cast parts for motors are manufactured in this factory. ROBOTS are used throughout the process, performing casting, unloading, bending and deburring.



## Mold Factory

Headquarters Mibu

ROBOSHOTS are used to produce plastic parts for CNCs, Servo Motors, Servo Amplifiers and ROBOTS. The molding status is constantly monitored and recorded via a network.



## Sheet Metal Factory

Headquarters

The Sheet Metal Factory manufactures cabinets for FANUC ROBOT controllers, using highly robotized systems.



## Paint Factory

Headquarters Tsukuba

At the Paint Factory in Headquarters, Servo Motor parts and ROBOT parts are painted, while at the Paint Factory in Tsukuba, ROBOT parts are painted. ROBOTS are used to automate the painting, washing and masking processes.



Support for industrial automation around the world  
**Global Service Network**

FANUC exerts all efforts to support customers in over 100 countries, through more than 280 service locations worldwide.



To our website

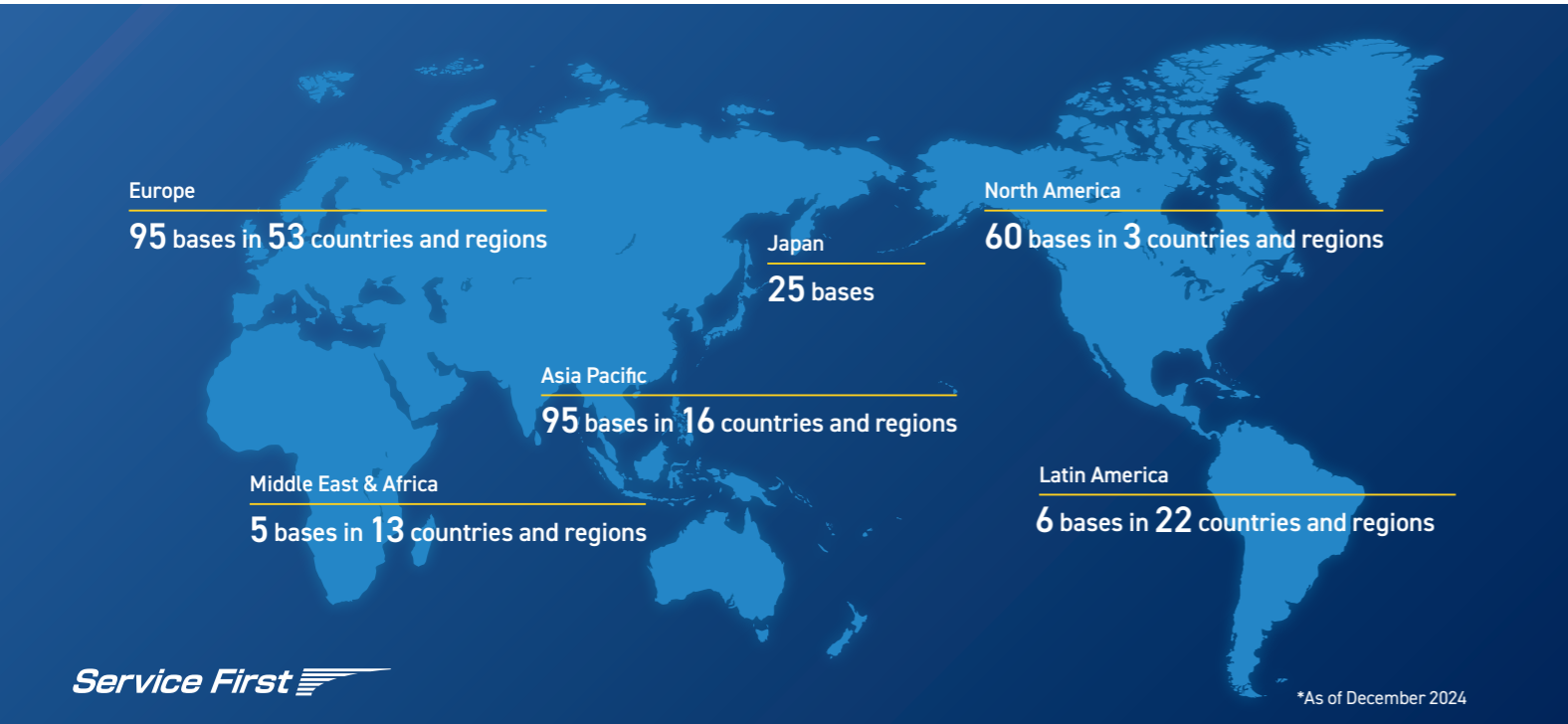

**Overseas Bases**

**North America & Latin America**

FANUC America Corporation

**Europe, Middle East & Africa**

FANUC Europe Corporation, S.A.

FANUC SOUTH AFRICA (PROPRIETARY) LIMITED

**Asia Pacific**

BEIJING-FANUC Mechatronics CO., LTD. (CNC, Laser)

SHANGHAI-FANUC Robotics CO., LTD. (Robot)

SHANGHAI-FANUC ROBOMACHINE CO., LTD. (Robomachine)

KOREA FANUC CORPORATION

TAIWAN FANUC CORPORATION

FANUC INDIA PRIVATE LIMITED

FANUC THAI LIMITED

FANUC MECHATRONICS (MALAYSIA) SDN. BHD.

PT. FANUC INDONESIA

FANUC SINGAPORE PTE. LTD.

FANUC PHILIPPINES CORPORATION

FANUC VIETNAM COMPANY LIMITED

FANUC OCEANIA PTY. LIMITED

**Domestic Service Bases**

Hino Branch

Osaka Branch

Hokkaido Branch

Tohoku Branch

Tsukuba Branch

Maebashi Branch

Echigo Branch

Hakusan Branch

Chugoku Branch

Hiroshima Branch

Kyushu Branch

Nagoya Service Center

Urawa Service Center

Yamanashi Service Center

Yokohama Service Center

Nagano Service Center

Hamamatsu Service Center

Mikawa Service Center

Toyama Service Center

Hirakata Service Center

Kokura Service Center

Others

Maintenance is offered for as long as our customers use our products with  
**Lifetime Maintenance**

“Lifetime maintenance” is one of our unique strengths. FANUC can provide over 16,000 kinds of repairs using more than 470 pieces of equipment and has repaired over 2.1 million items. We retain over 17,000 types of repair parts - including those for discontinued products - with a stock of more than 3 million parts. Repair data serves as a valuable knowledge base for FANUC’s repair departments around the world, and is also fed back to product development departments.



**Service Structure Aiming for a High Operating Rate**

We have service call centers and spare parts warehouses in all major locations around the world to maximize our customers’ uptime.

**Call Center**

Experienced engineers with comprehensive knowledge of FANUC’s FA, ROBOT and ROBOMACHINE products, quickly respond to customers’ questions and requests for service.



**Spare Parts Warehouse**

FANUC’s service offices around the world have an abundant stock of spare parts in their warehouses. The Parts Centers in the Hino Branch and Nagoya Service Center stock parts from those of old models up to the latest models, which are capable of being shipped 24 hours a day. The Global Warehouse stores spare parts to replenish the warehouses worldwide and contributes to maximizing our global customers’ operating rates.



**Digital Technology for More Convenience**

**FabriQR Contact**

FabriQR Contact is an inquiry service using smartphones. By scanning a 2D code on the screen with a smartphone, device information, alarm information, and other necessary data are automatically transferred to a FANUC service base. The time for solving problems can be shortened as FANUC service personnel can understand the state of the device accurately and quickly, as well as by referencing information from the customer.

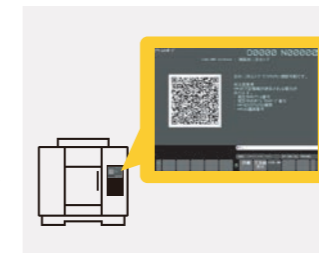

**ZDT (Zero Down Time)**

ZDT is a practical IoT product that eliminates unexpected downtime, by providing comprehensive robot maintenance and diagnostic functions. With ZDT, downtime can be reduced to zero, through failure prediction, traceability, preventive maintenance, and system monitoring. ZDT supports both cloud and on-premise configurations.

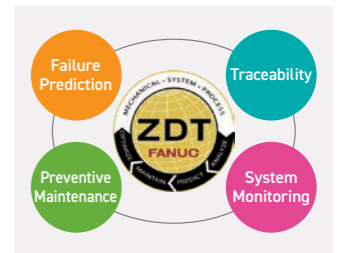

# FANUC Academy

FANUC Academy is equipped with spacious classrooms, various types of hands-on training equipment and training systems, and offers exercise-based courses that are immediately effective in trainees' jobs, so that customers can make good use of FANUC products in their businesses. Trainees can have a fulfilling stay during their training at the adjacent accommodation, FANUC Guesthouse, which has comfortable guest rooms, a large bathhouse, and other facilities.



## Three Training Courses

### Academy Courses



In face-to-face trainings at the Academy, an abundance of real machines are available with which trainees can practice after lectures. If there are any questions, the instructor will answer on the spot and provide guidance.

### Live Seminars



Through live seminars, trainees can participate in high-level courses at home or in their offices without physically coming to the FANUC Academy. Questions can be posed freely to experienced instructors.

### On-Demand Seminars

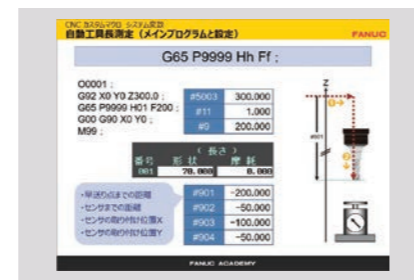

On-demand seminars offer the opportunity to learn sophisticated technology through materials and videos, at any time, in any place.

# FANUC's Sustainability

Since its foundation, FANUC has pursued industrial automation across the manufacturing industry and other industries. We create economic and social values by automating and robotizing customers' businesses and contributing to solving social and environmental issues, through incessant technological innovation.

## 1 | Promotion of Various Initiatives to Achieve Carbon Neutrality



Reducing GHG Emissions



Reducing Power Consumption



Utilizing Green Energy

## 2 | Support Users to Achieve SDGs through Business Activities and Product Functions

**2** ZERO HUNGER  

**3** GOOD HEALTH AND WELL-BEING  

**4** QUALITY EDUCATION  

**7** AFFORDABLE AND CLEAN ENERGY  

**8** DECENT WORK AND ECONOMIC GROWTH  

**9** INDUSTRY, INNOVATION AND INFRASTRUCTURE  

**12** RESPONSIBLE CONSUMPTION AND PRODUCTION  

**13** CLIMATE ACTION  

## CONCRETE APPROACHES

### Introduction of Solar Energy Equipment

FANUC has solar energy equipment with a total capacity of 8.6 MW and plans to introduce additional equipment to increase this to 14.6 MW by FY2026.



### Support of the WorldSkills Competition as a Global Industry Partner

Since 2018, FANUC, as a world-leading industrial robot manufacturer, has supported WorldSkills, an international charity that organizes world and national championships for vocational skills.



### Participation in External Initiatives



**Task Force on Climate-related Financial Disclosures (TCFD)**  
 FANUC expressed its support for the recommendations of the Task Force on Climate-related Financial Disclosures (TCFD) in December 2021.

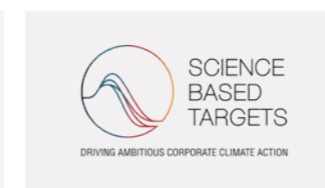

**SBT Initiative**  
 The targets to reduce GHG emissions by FY2030 have been certified by the SBT (Science Based Targets) initiative.

### External Assessment

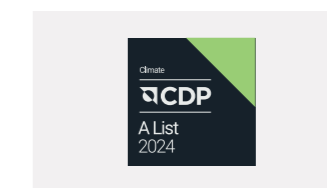

**CDP**  
 FANUC has been recognized as an "A List" company, which is the highest ranking in the climate change category of CDP (Carbon Disclosure Project), for two consecutive years.



**MSCI\***  
 Since 2023, Fanuc has received MSCI's (Morgan Stanley Capital International) highest ESG rating of "AAA."

\*THE USE BY FANUC CORPORATION OF ANY MSCI ESG RESEARCH LLC OR ITS AFFILIATES ("MSCI") DATA, AND THE USE OF MSCI LOGOS, TRADEMARKS, SERVICE MARKS OR INDEX NAMES HEREIN, DO NOT CONSTITUTE A SPONSORSHIP, ENDORSEMENT, RECOMMENDATION, OR PROMOTION OF FANUC CORPORATION BY MSCI. MSCI SERVICES AND DATA ARE THE PROPERTY OF MSCI OR ITS INFORMATION PROVIDERS, AND ARE PROVIDED 'AS-IS' AND WITHOUT WARRANTY. MSCI NAMES AND LOGOS ARE TRADEMARKS OR SERVICE MARKS OF MSCI.

# Company Overview

Company Name	FANUC CORPORATION
Established	May 12, 1972
Paid-in Capital	69 billion yen
Number of Employees	10,113 (consolidated), 4,793 (non-consolidated) *As of March 2025
Headquarters	3580 Shibokusa, Oshino-mura, Minamitsuru-gun, Yamanashi, 401-0597, JAPAN
Performance (FY2024)	Net sales 7,971 hundred million yen Ordinary income 1,967 hundred million yen Net income 1,476 hundred million yen

## Management As of July 1, 2025

Representative Director, President and CEO	Kenji Yamaguchi	
Directors	Ryuji Sasuga	(Senior Managing Officer and CFO, General Manager, Corporate Finance & Facility Planning Division)
	Michael J. Cicco	(President and CEO, FANUC America Corporation)
	Naoko Yamazaki	(Outside Director)
	Hiroto Uozumi	(Outside Director)
	Yoko Takeda	(Outside Director)
	Toshiya Okada	(Standing Audit & Supervisory Committee Member)
	Dr. Eng. Hidetoshi Yokoi	(Audit & Supervisory Committee Member, Outside Director)
	Mieko Tomita	(Audit & Supervisory Committee Member, Outside Director)
	Shigeo Igashima	(Audit & Supervisory Committee Member, Outside Director)
Executive Managing Officers	Hiroshi Noda	(General Manager, FA Research & Development Division, General Manager, Research & Development Promotion Division)
	Yoshihiro Gonda	(General Manager, General Affairs, Legal & Procurement Division)
Senior Managing Officers	Tomoaki Ishibe	(General Manager, FA Sales Division)
	Kenichiro Abe	(General Manager, Robot Research & Development Division, General Manager, Robot Mechanical Research & Development Division, General Manager, Robot Application Engineering Division)
	Dr. Eng. Yasusuke Iwashita	(General Manager, CNC Software Research & Development Division, FA Research & Development Division)
	Dr. Eng. Satoshi Takatsugi	(General Manager, Robomachine Research & Development Division, General Manager, Robomachine Sales Division, General Manager, Sales Promotion Division)
	Seigo Kato	(General Manager, Robot Software Research & Development Division, Robot Research & Development Division)
Managing Officers	Masamoto Fukuda	(General Manager, Servo Research & Development Division, FA Research & Development Division)
	Naoki Shimada	(General Manager, ROBOT Sales Division)
	Yuichi Endo	(Deputy General Manager, Production Division, President, FANUC SERVO LTD)
	Tatsuo Shinohara	(General Manager, Electronics Production Division, Production Division)
	Jun Ebina	(General Manager, Human Resources Division)
Special Advisor	Dr. Eng. Yoshiharu Inaba	

## Organizational Chart As of July 1, 2025

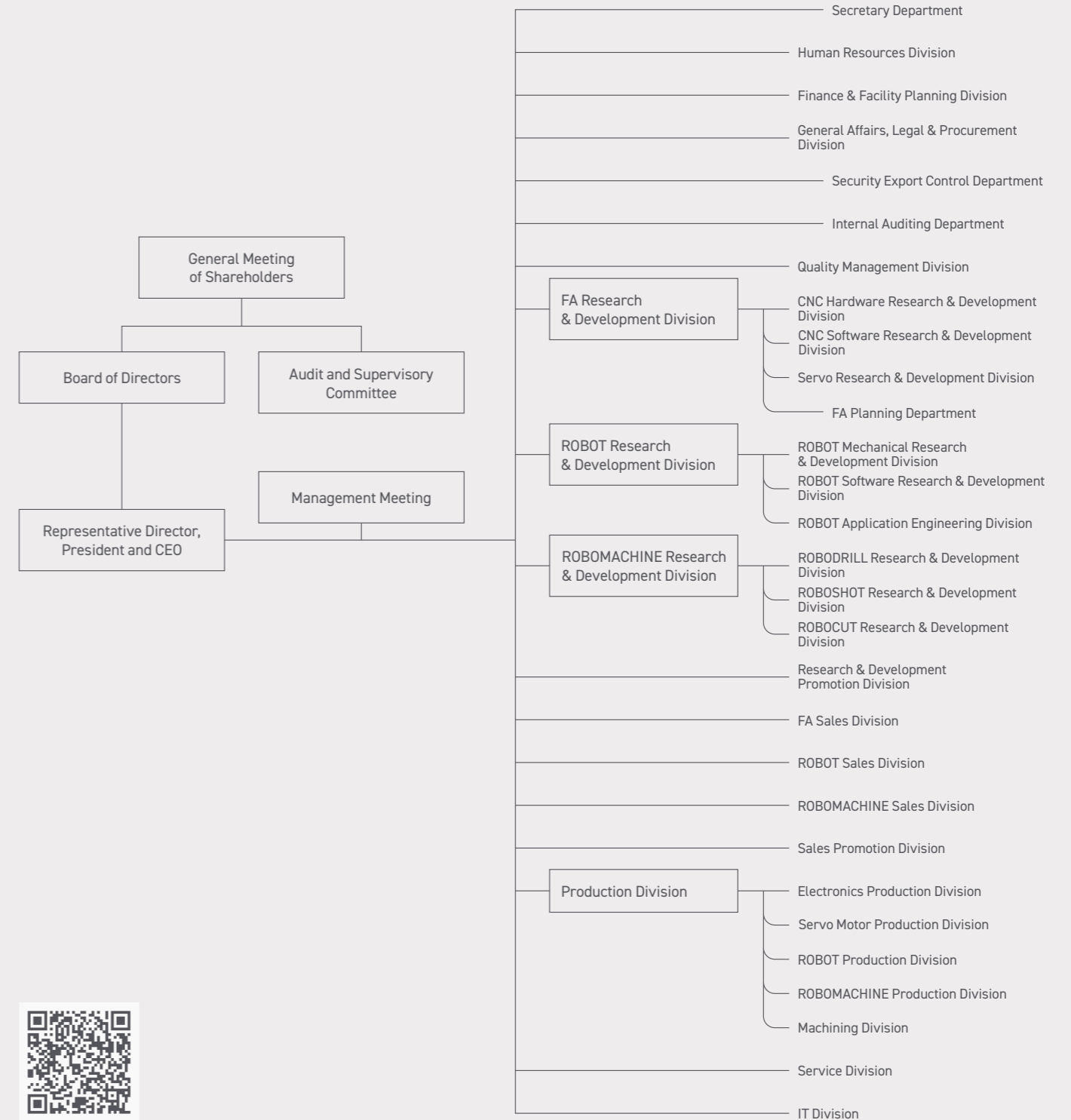

To our website

# FANUC's History

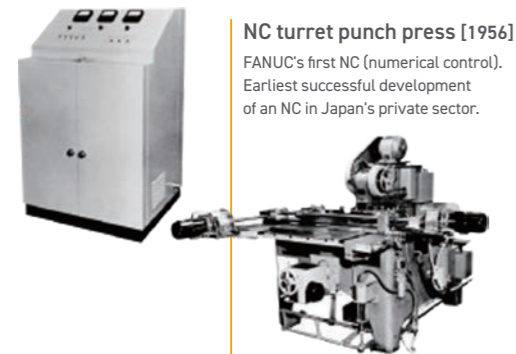

**FANUC 250 [1964]**  
First CNC developed by FANUC.

**NC turret punch press [1956]**  
FANUC's first NC (numerical control). Earliest successful development of an NC in Japan's private sector.



**FANUC-DRILL [1972]**  
FANUC developed an NC drilling machine in order to spread the use of NC machine tools.



**FANUC AUTOSHOT [1984]**  
FANUC developed the first electric injection molding machine in the world for mass production.

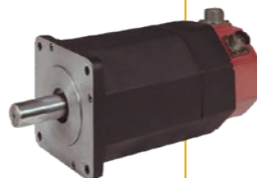

**AC Servo Motor [1982]**  
Beginning of the AC Servo Motor. Maintenance was not required due to being brushless.

**DD Motor [2003]**  
FANUC's first DD motor. Contributed to high-speed, high-precision 5-axis machining.



**FS30i/31i/32i [2003]**  
FANUC's highest positioned model developed by renewing hardware components.



**ROBOCUT α-CiC [2021]**  
Renewed the machine structure, discharge device and discharge control to significantly improve high-speed, high-precision cutting performance.

**ROBOSHOT α-SiB [2021]**  
Excellent operability with a display unit having the largest screen in the industry and an original dual-screen simultaneous display function.



1950

1960

1970

1980

1990

2000

2010

2020

**Electric Pulse Motor [1967]**  
Pulse motor capable of driving machine tools with just electricity, without using hydraulics.



**Electrohydraulic Pulse Motor [1959]**  
Origin of FANUC's servo technology. Contributed to establishing FANUC's position in the NC market.



**FANUC TAPE CUT-SERIES A [1975]**  
FANUC developed an electric discharge machine in order to spread the use of NC machine tools.

**FANUC ROBOT MODEL 1 [1977]**  
Developed as FANUC's first robot product. Cylindrical coordinate type with simultaneous single axis control.



**LR Mate [1992]**  
ROBOT for loading and unloading workpieces to and from machine tools. The name originates from the abbreviation of "Loader Robot."



**R-2000iA [2000]**  
Robot that is representative of FANUC, born from a major renovation of former robots and released in 2000.



**ROBODRILL α-DiB [2016]**  
Advanced high performance version with new mechanical parts and a servo turret. Expanded the market for ROBODRILL.



**CRX-10iA [2019]**  
New collaborative robot series focused on safety, ease of use and high reliability.



**FS500i-A [2023]**  
Latest CNC series adapting to the changing times by fully changing the 5-axis control software and enhancing security measures.



1955

A project team to develop NCs was established in FUSI TSUSHINKI SEIZO K.K. (presently Fujitsu Limited).

1965

Licensed to Siemens AG in West Germany to manufacture and sell pulse motors.

1972

FUJITSU FANUC LTD established.

1974

DC servo motor was licensed from Gettys Manufacturing Co.

1977

FANUC U.S.A. Corporation established as a service subsidiary.

1978

KOREA NUMERIC CORPORATION jointly established by FANUC and Hwacheon Machinery Works Co.  
FANUC Europe S.A. established as a service subsidiary.

1982

Company name changed to FANUC LTD. GMFanuc Robotics Corporation jointly established in the U.S. by FANUC and General Motors.

1983

Listed on the first section of the Tokyo Stock Exchange.

1984

Relocation of headquarters to the foot of Mount Fuji.

1986

FANUC TAIWAN LTD established.  
GE Fanuc Automation Corporation jointly established in the U.S. by FANUC and General Electric.

1992

BEIJING-FANUC Mechatronics CO., LTD. jointly established with Beijing Machine Tool Research Institute.  
FANUC INDIA PRIVATE LIMITED established.  
Acquired 100% ownership of GMFanuc Robotics and restructured it as FANUC Robotics North America, Inc. and FANUC Robotics Europe S.A.

1997

SHANGHAI-FANUC Robotics CO., LTD. jointly established in China with Shanghai Electric Group Company Limited.

2009

Dissolved joint venture with General Electric.

2013

European subsidiaries reorganized to form FANUC Europe Corporation.  
Subsidiaries in the Americas reorganized to form FANUC America Corporation.

2016

Reliability Evaluation Building and Performance Evaluation Building completed.

2020

Founder and Honorary Chairman, Dr. Seiueemon Inaba, Ph.D. in Engineering, passed away.

2022

Total production of 5 million CNC units achieved.

2023

Total shipment of 1 million FANUC ROBOTS achieved.

